

## Operating Instructions

### Full height turnstile

### MPT-333



## **Original Operating Instructions**

This document is available as PDF in the Magnetic Autocontrol download area ([www.magnetic-access.com](http://www.magnetic-access.com)). Authorisation is required for download.

### **MAGNETIC AUTOCONTROL GMBH**

Grienmatt 20  
D-79650 Schopfheim  
Germany

Phone +49 7622 695 5  
Fax +49 7622 695 802  
[info@magnetic-germany.com](mailto:info@magnetic-germany.com)  
[www.magnetic-access.com](http://www.magnetic-access.com)

## Contents

---

<b>1</b>	<b>Notices on the document</b>	<b>7</b>
1.1	Purpose and contents of these operating instructions	7
1.2	Reading and storing the operating instructions	7
1.3	Non-observance of the operating instructions	8
1.4	Symbols and illustrations used in the operating instructions	8
1.4.1	Warning notes and notices	8
<b>2</b>	<b>Safety</b>	<b>10</b>
2.1	Intended use	10
2.2	Changes and modifications	10
2.3	Target groups	11
2.3.1	Operator and its responsibility	11
2.3.2	Personnel – activities and qualifications	12
2.4	Personal protective equipment	13
2.5	Symbols on the device	14
2.6	For your safety	14
2.7	To protect the environment	15
2.8	Emergency opening the pedestrian gate	15
2.9	Earthing support beam, cover, and service door	16
<b>3</b>	<b>Technical data</b>	<b>18</b>
3.1	Dimensions and design	18
3.1.1	MPT-333 (3x120°)	18
3.1.2	MPT-333 (3x120°) with “KHSB” option	21
3.1.3	MPT-333 (4x90°)	24
3.2	Electrical connection	27
3.3	Operating conditions	27
3.4	Emissions	27
3.5	Control unit MGC	28

---

---

<b>4</b>	<b>Design and function</b>	<b>29</b>
4.1	Design	29
4.1.1	MPT-333 (3x120°)	29
4.1.2	MPT-333 (3x120°) with “KHSB” option	30
4.1.3	MPT-333 (4x90°)	31
4.2	Function	32
4.3	Definitions and versions	33
<hr/>		
<b>5</b>	<b>Receipt of goods, transport, and storage</b>	<b>35</b>
5.1	Receipt of goods	35
5.2	Safety during transport	35
5.3	Transport	37
5.4	Storage	37
<hr/>		
<b>6</b>	<b>Unpacking, scope of delivery and identification</b>	<b>38</b>
6.1	Unpacking	38
6.2	Scope of delivery	39
6.3	Identification	40
6.3.1	Type plate	40
<hr/>		
<b>7</b>	<b>Mounting</b>	<b>41</b>
7.1	Safety during mounting	41
7.2	Mounting options and notices, attachment material	42
7.2.1	Overview	42
7.2.2	Directly on the foundation	42
7.2.3	Optional base frame	43
7.3	Required steps	43
7.4	Specifying the mounting position	44
7.5	Building the foundation and laying empty conduits	44
7.5.1	Foundation requirements	44
7.5.2	Empty conduits requirements	46
7.5.3	Building the foundation and laying empty conduits	46
7.5.4	Foundation and empty conduit plan MPT-333 (3x120°)	47
7.5.5	Foundation and empty pipe plan MPT-333 (3x120°) with “KHSB” option	48
7.5.6	Foundation and empty conduit plan MPT-333 (4x90°)	49
7.6	Preliminary work for mounting directly on the foundation	50

---

7.7	Mounting the MPT-333 (3x120°) without and with option “KHSB”	51
7.7.1	Mounting the locking comb or option “KHSB” MPT-333 (3x120°)	52
7.7.2	Mounting the cage half MPT-333 (3x120°)	54
7.7.3	Mounting the support beam MPT-333 (3x120°)	55
7.7.4	Mounting the floor bearing and centre pillar MPT-333 (3x120°)	58
7.7.5	Connecting two pedestrian gates MPT-333 (3x120°)	64
7.7.6	Closing the cover of the support beam MPT-333 (3x120°)	64
7.8	Mounting the MPT-333 (4x90°)	66
7.8.1	Mounting the locking comb and cage half MPT-333 (4x90°)	66
7.8.2	Mounting the support beam MPT-333 (4x90°)	68
7.8.3	Mounting the floor bearing and centre pillar MPT-333 (4x90°)	71
7.8.4	Connecting two pedestrian gates MPT-333 (4x90°)	77
7.8.5	Closing the cover of the support beam MPT-333 (4x90°)	77
7.9	Checking the mounting	78
<b>8</b>	<b>Mounting the optional mounting pillar for access-control devices</b>	<b>79</b>
<b>9</b>	<b>Electrical connection</b>	<b>87</b>
9.1	Safety during electrical connection	87
9.2	Installing electrical protective devices	88
9.3	Opening and closing the cover or service door	89
9.3.1	Opening and closing the cover	89
9.3.2	Opening and closing the service door	91
9.4	Connecting the mains cable	92
9.5	Connecting customer control lines	93
9.6	Connecting emergency opening contacts	94
9.7	Mounting and connecting customer access-control devices	94
9.8	Checking the electrical connections	95
<b>10</b>	<b>Commissioning</b>	<b>96</b>
10.1	Safety during commissioning	96
10.2	Putting the pedestrian gate into operation	96
10.3	Switching the pedestrian gate on and off	97
10.4	Parameterising the pedestrian gate	98

---

<b>11</b>	<b>Operation</b>	<b>98</b>
<b>12</b>	<b>Log book</b>	<b>98</b>
<b>13</b>	<b>Cleaning and maintenance</b>	<b>99</b>
13.1	Safety during cleaning and maintenance	99
13.2	Cleaning the pedestrian gate	100
13.2.1	Cleaning the pedestrian gate from the outside	100
13.2.2	Cleaning the support beam from the inside	101
13.3	Maintenance schedule	101
<b>14</b>	<b>Corrective action</b>	<b>102</b>
<b>15</b>	<b>Spare parts and repair</b>	<b>103</b>
15.1	Spare parts	103
15.2	Changing and adjusting proximity sensors	103
<b>16</b>	<b>Conversion</b>	<b>106</b>
16.1	Safety during conversion	106
16.2	Converting the locking unit	106
<b>17</b>	<b>Customer service</b>	<b>110</b>
<b>18</b>	<b>Decommissioning</b>	<b>111</b>
18.1	Safety during decommissioning	111
18.2	Taking the pedestrian gate out of service	111
<b>19</b>	<b>Dismounting and disposal</b>	<b>112</b>
19.1	Safety during dismounting and disposal	112
19.2	Dismounting and disposal of the system	112
<b>20</b>	<b>EU Declaration of Conformity</b>	<b>113</b>
	<b>Index</b>	<b>115</b>

---

# 1 Notices on the document

## 1.1 Purpose and contents of these operating instructions

These operating instructions provide all the information required for the product in the various phases of its life cycle.

These operating instructions contain the following information: Design and function, transport and storage, unpacking and delivery, installation and mounting, electrical connection, commissioning, operation, cleaning and maintenance, decommissioning, dismantling, and disposal.



### IMPORTANT!

For the parameterisation of the control unit MGC and trouble-shooting, see the separate document "Description control unit MGC (Doc.ID: 58170027)".

---

## 1.2 Reading and storing the operating instructions

Compliance with all indicated safety notices, warning notes, and instructions is a prerequisite for safe work. In addition, the local accident prevention regulations, general safety regulations and local environmental regulations applicable to the area of application of the product must be observed.

Carefully read these operating instructions before starting any work! The operating instructions are part of the product and must be kept in direct proximity of the product and well accessible to the personnel at all times.

When passing the product on to third parties, these operating instructions must also be handed over.

### 1.3 Non-observance of the operating instructions

Magnetic declines all liability for personal injury and property damage caused by not observing the operating instructions.

This applies in particular to damage caused by:

- › Improper use
- › Use of non-qualified personnel
- › Use of non-approved components
- › Arbitrary modifications
- › Inappropriate mounting and installation
- › Incorrect operation
- › Inadequate or omitted maintenance and repairs
- › Use of non-approved spare parts
- › Operating a defective product



### 1.4 Symbols and illustrations used in the operating instructions



#### 1.4.1 Warning notes and notices

Warning notes are characterised by pictograms in these instructions. A warning note starts with a signal word that expresses the extent of the hazard.

It is absolutely essential to observe the warning notes and to proceed with caution in order to prevent accidents as well as personal injuries and property damage.

#### Warning notes

 <b>DANGER</b>	
	The signal word DANGER points to an immediately dangerous situation, which leads to death or severe injuries if it is not avoided.

 <b>WARNING</b>	
	The signal word WARNING indicates a potentially dangerous situation, which can lead to death or severe injuries if not avoided.



**⚠ CAUTION**

The signal word CAUTION indicates a potentially dangerous situation, which can lead to minor injuries if not avoided.

**NOTICE**

The signal word NOTICE indicates a potentially harmful situation, which leads to property damage if not avoided.

**Notes and recommendations**

---

**IMPORTANT!**

The signal word IMPORTANT highlights useful notes and recommendations as well as information for an efficient and trouble-free operation.

---

## **2 Safety**

### **2.1 Intended use**

The Magnetic pedestrian gate MPT is intended only for access control of persons from a zone not controlled (ZNC) to a zone controlled (ZC).

In general, the pedestrian gate is integrated in the fence and gate systems.

The pedestrian gate is intended for passage of persons who can pass the pedestrian gate safely, quickly, and without any assistance. Separate means of access must be provided for persons who cannot pass through the pedestrian gate safely, quickly, or without assistance, such as small children, elderly people, or people with disabilities. Children under 14 years of age must only pass through the pedestrian gate under the supervision of an adult.

The pedestrian gate must only be mounted on non-flammable floors.

The pedestrian gate must only be operated within the temperature range indicated on the type plate.

Prevent children playing with the power operated pedestrian entrance control equipment.

Dashing through a moving power operated pedestrian entrance control equipment can lead to severe injuries.

#### **Misuse**

Any use differing from or beyond this is considered improper use. Magnetic is not liable for any resulting personal injury or damage to property.

For example, the following applications are regarded as improper use:

- › Use of the pedestrian gate by unaccompanied children under 14 years of age.
- › Use of the pedestrian gate by persons who cannot pass the pedestrian gate safely, quickly or without assistance.
- › Use of the pedestrian gate without released passage. This means that the centre pillar is forced to rotate.
- › Mounting of the pedestrian gate on flammable ground.

### **2.2 Changes and modifications**

Modifications and conversions to the product, to an attachment or to one of the components can lead to unforeseen dangers. Magnetic's written approval must be obtained before any technical modifications or alterations are made to the product or any of its components.

## 2.3 Target groups

### 2.3.1 Operator and its responsibility

The operator must comply with the statutory obligations regarding work safety. In addition to the safety instructions and warning notes in these operating instructions, the valid safety, accident prevention, and environmental protection regulations must be observed.

In particular, the operator must:

- › determine additional danger in a danger analysis
- › implement the necessary behavioural requirements in work instructions for operation with the product at the operating location
- › regularly verify throughout the product time of use that the work instructions drawn up by them comply with the current state of the regulations
- › adjust the working instructions to any new provisions, standards, and usage conditions – where required.
- › clearly regulate the responsibilities for all work on the product and with the product such as mounting, commissioning, operation, cleaning, maintenance, etc.
- › ensure that personal protective equipment is worn
- › ensures that all employees who work with the product or on the product have read and understood the operating instructions.

Furthermore, the operator must train personnel regarding the use of the product at regular intervals and provide information on possible dangers.

Furthermore, the operator is responsible for:

- › the product is always in perfect technical condition.
- › the product is maintained at specified maintenance intervals
- › the product is only operated within the permitted temperature range.

The operator is also responsible for ensuring that the danger area of the product cannot be accessed by any unauthorised persons under any circumstances.

### 2.3.2 Personnel – activities and qualifications

Only authorised, trained, and sufficiently qualified personnel may work on and with the product. The personnel must know and have understood the operating instructions and the required operating procedures.

Designation	Qualification
Transport equipment operator	<ul style="list-style-type: none"> <li>› Has professional experience as a transport equipment operator or warehouse and transport worker.</li> <li>› Has a valid driving licence for the required industrial truck, e.g., forklift.</li> <li>› Knows the necessary regulations.</li> <li>› Can evaluate the work assigned to them, recognise possible dangers, and take appropriate safety measures.</li> </ul>
Technician	<ul style="list-style-type: none"> <li>› Has completed training as a systems mechanic, machinery technician, installation mechanic, installation technician or has comparable technical training.</li> <li>› Has completed training as an electrical safety expert.</li> <li>› Has additional knowledge and experience.</li> <li>› Knows the relevant technical terms and regulations.</li> <li>› Can evaluate the work assigned to them, recognise possible dangers, and take appropriate safety measures.</li> </ul>
Qualified electrician	<ul style="list-style-type: none"> <li>› Has technical training which entitles them to carry out and monitor electrical work for commercial purposes.</li> <li>› Has additional knowledge and experience.</li> <li>› Knows the relevant technical terms and regulations.</li> <li>› Can evaluate the work assigned to them, recognise possible dangers, and take appropriate safety measures.</li> </ul>
Operator	<ul style="list-style-type: none"> <li>› Trained by the operator.</li> </ul>

Table 1: Qualifications of personnel

Task	Transport equipment operator	Technician	Qualified electrician	Operator
Transporting	X	X	–	–
Unpacking	X	X	X	–
Laying the foundation	–	X	–	–
Mounting	–	X	X	–
Electrical connection	–	X	X	–
Parameterisation	–	X	X	–
Commissioning <sup>1)</sup>	–	X	X	–
Operating	–	X	X	X
Cleaning <sup>2)</sup>	–	X	X	X
Servicing <sup>3)</sup>	–	X	X	–
Troubleshooting	–	X	X	–
Repairing	–	X	X	–
Decommissioning	–	X	X	–
Dismounting	–	X	X	–
Disposing	–	X	X	–

1) As per the supplied log book "Full height turnstile with bicycle access MPT-333 / MPT-333"

2) According to the maintenance plan in these operating instructions

3) At least once a year in accordance with the supplied log book

Table 2: Activities and qualifications

## 2.4 Personal protective equipment

It is necessary to wear personal protective equipment when dealing with the product so as to minimise health hazards.

Properly dress in the necessary protective equipment such as work clothes, protective gloves, safety shoes, etc. before performing any work and wear this during work.

## 2.5 Symbols on the device

---



### Warning of electric voltage!

The warning sign indicates dangerous areas with dangerous electric voltage. Non-observance of the warning signs causes severe injuries or death. The work to be done must only be performed by a qualified electrician or an electrical safety expert.

This warning sign is fixed at the following point:

- › At the terminals, under the cover.
- 

## 2.6 For your safety

---



### Mortal danger by electric voltage!

Touching live parts can be lethal. Damage to the insulation or to individual components can be lethal.

- › If the insulation or any other parts are damaged, switch off the power supply at once and arrange for repairs.
  - › Only qualified electricians or electrical safety experts may perform any work on the electrical system.
  - › Before commencing any work, switch off power supply and secure against restarting. Test for absence of voltage.
  - › Perform the electrical installation in accordance with the applicable regulations.
  - › Install protective devices that are required by national and local regulations, such as e.g., residual current devices. These protective devices must be provided by the customer.
  - › Observe the information on the type plate.
  - › Close all covers after all work is completed.
  - › Keep moisture and dust away from live parts. Intruding moisture and dust may cause a short circuit.
  - › If the electrical connection is made during precipitation, e.g., rain or snow, prevent the intrusion of moisture by means of suitable protective covers.
  - › During or after a lightning struck the system, touching the components or being in the immediate vicinity of the system poses a danger to life. When mounting outside, do not install and mount the pedestrian gate during thunderstorms.
-

## 2.7 To protect the environment

---



### **Improper disposal!**

Improper disposal can result in damage to the environment.

- › Dispose of the product in accordance with local and national laws and regulations.
  - › Sort resources and supply them to recycling.
- 

## 2.8 Emergency opening the pedestrian gate

↗ Page 94, chapter 9.6.

## 2.9 Earthing support beam, cover, and service door



### IMPORTANT!

For safe operation, the support beam, the cover, and the service door must be earthed. Service door, cover, and support beam are earthed via protective earth conductors and earthing points. During operation, all protective earth conductors must be connected to the intended earthing points.

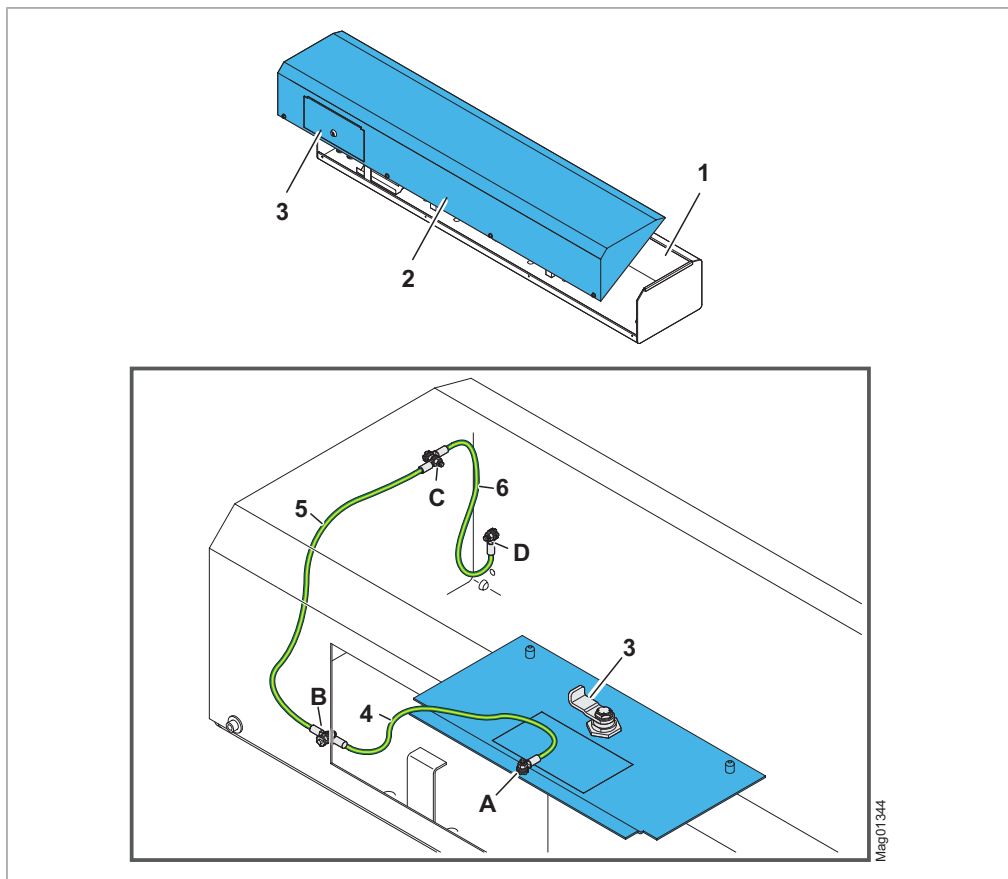

Fig. 1: Earthing support beam, cover, and service door (exemplary representation)

- 1 Support beam
- 2 Cover
- 3 Service door
- 4 Protective earth conductor for service door
- 5 Protective earth conductor for cover
- 6 Protective earth conductor for support beam
- A Earthing point service door (single) ↗ Page 17, Fig. 2
- B Earthing point cover (double) ↗ Page 17, Fig. 2
- C Earthing point support beam (double) ↗ Page 17, Fig. 2
- D Earthing point mounting panel support beam (single) ↗ Page 17, Fig. 2



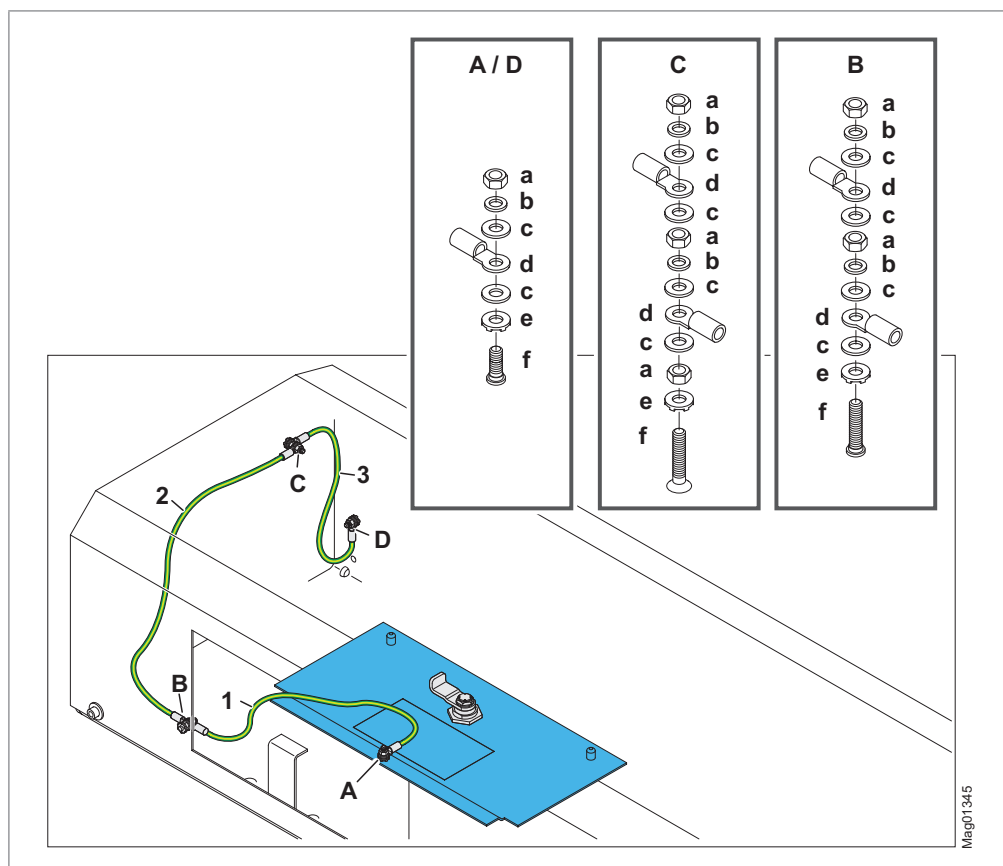

Fig. 2: Earthing points service door, cover and support beam (exemplary representation)

- A Earthing point service door (single)
  - B Earthing point cover (double)
  - C Earthing point support beam (double)
  - D Earthing point mounting panel support beam (single)
- 
- a Brass nut
  - b Schnorr fuse
  - c Brass disc
  - d Ring cable lug
  - e Contact disc
  - f Earthing bolt / Earthing screw
- 
- 1 Protective earth conductor for service door (protective earth conductor service door – cover)
  - 2 Protective earth conductor for cover (protective earth conductor for cover – support beam)
  - 3 Protective earth conductor for support beam (protective earth conductor mounting panel support beam – support beam)

### 3 Technical data

#### 3.1 Dimensions and design

##### 3.1.1 MPT-333 (3x120°)

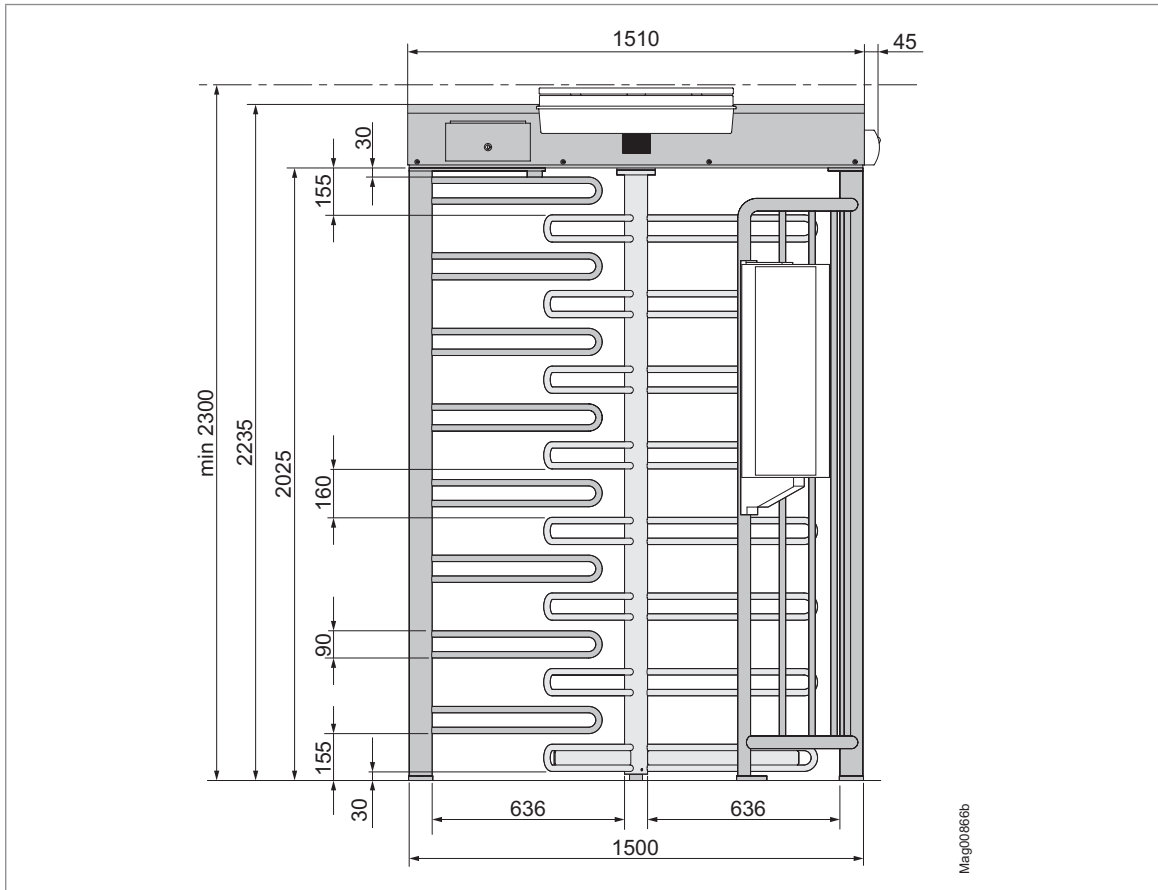

Fig. 3: Dimensions (size in mm) – MPT-333 (3x120°)  
View from zone controlled (ZC),  
Version “entrance side left” shown here  
Illumination, twilight switch, GED, and mounting pillars optional  
Required height min. 2300 mm to open the cover.

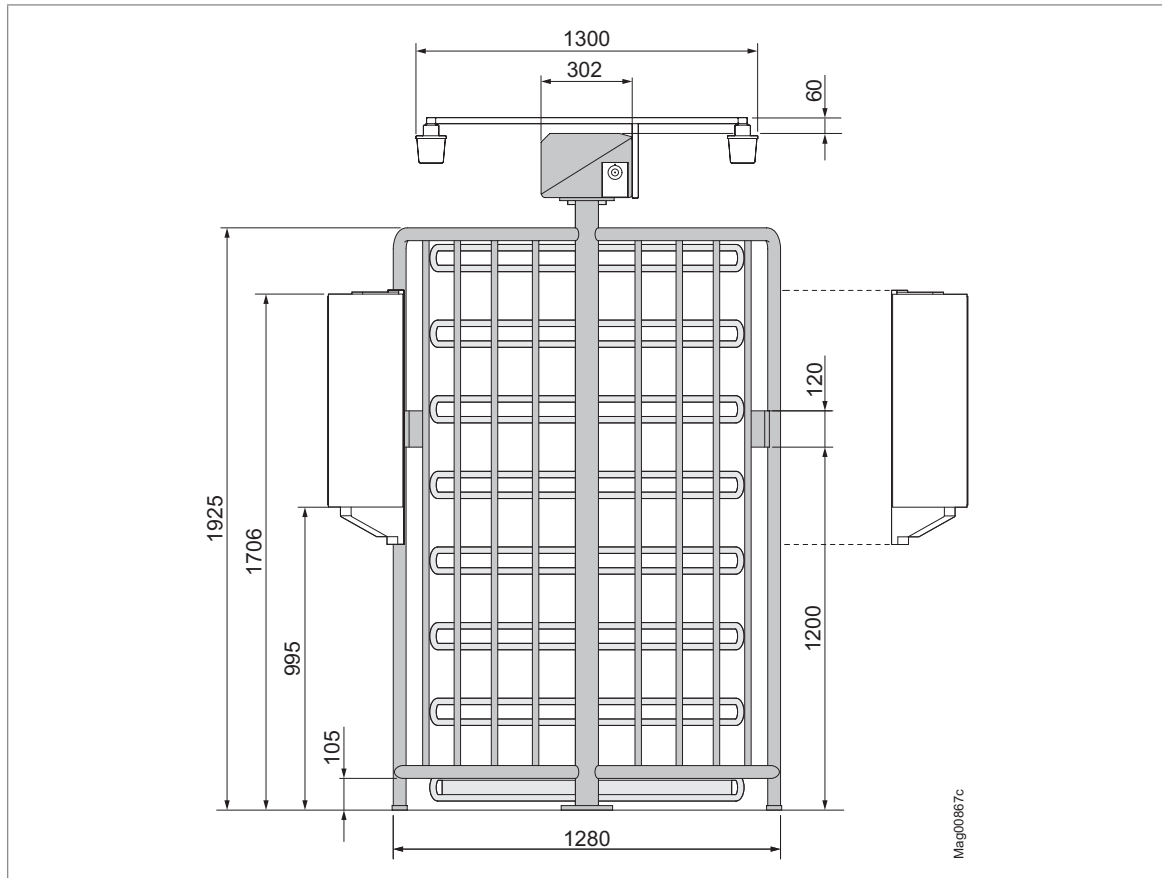

Fig. 4: Dimensions (size in mm) – MPT-333 (3x120°)  
Side view,  
Illumination, twilight switch, and mounting pillars optional,  
mounting height of mounting pillar for version by Magnetic

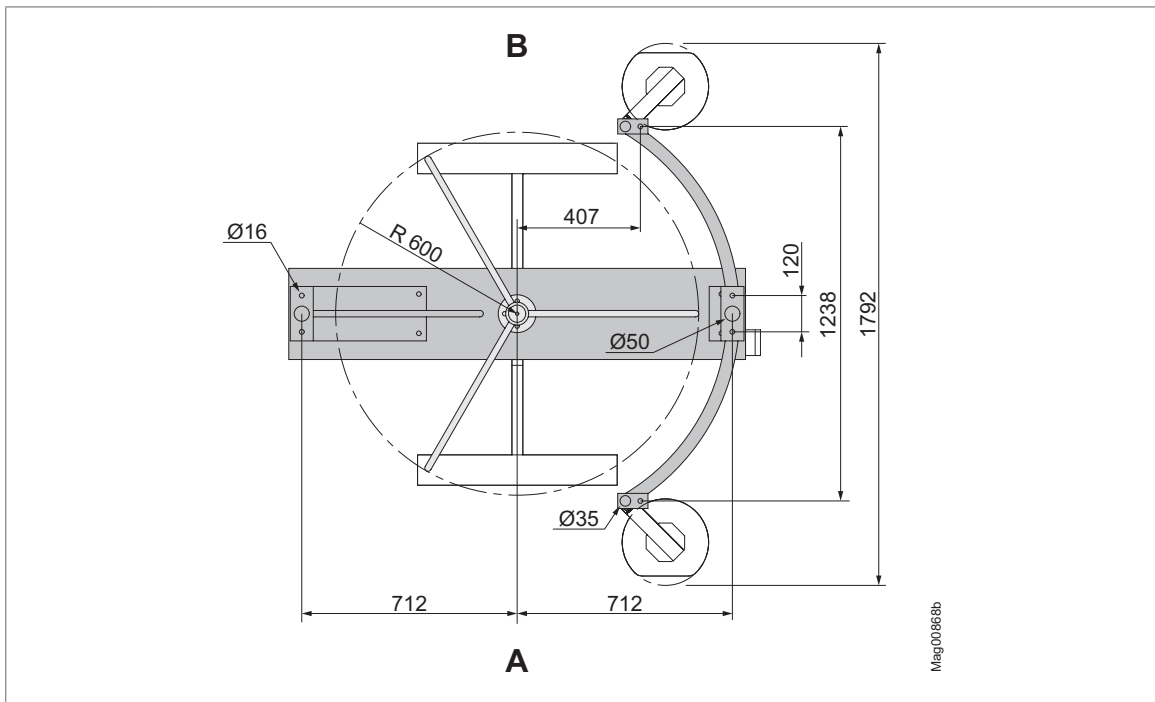

Fig. 5: Dimensions (size in mm) – MPT-333 (3x120°)  
 View from below,  
 Version “entrance side left” shown here,  
 Illumination, twilight switch, and mounting pillars optional  
 A Zone not controlled (ZNC)  
 B Zone controlled (ZC)

Designation	Value
Dimensions (width x depth x height)	1510 mm x 1288 mm x 2300 mm
Weight without attachments	250 kg
Material, coating, and colour	Depending on the version ordered: See order confirmation.

Table 3: Dimensions and design – MPT-x3x (3x120°)

### 3.1.2 MPT-333 (3x120°) with “KHSB” option

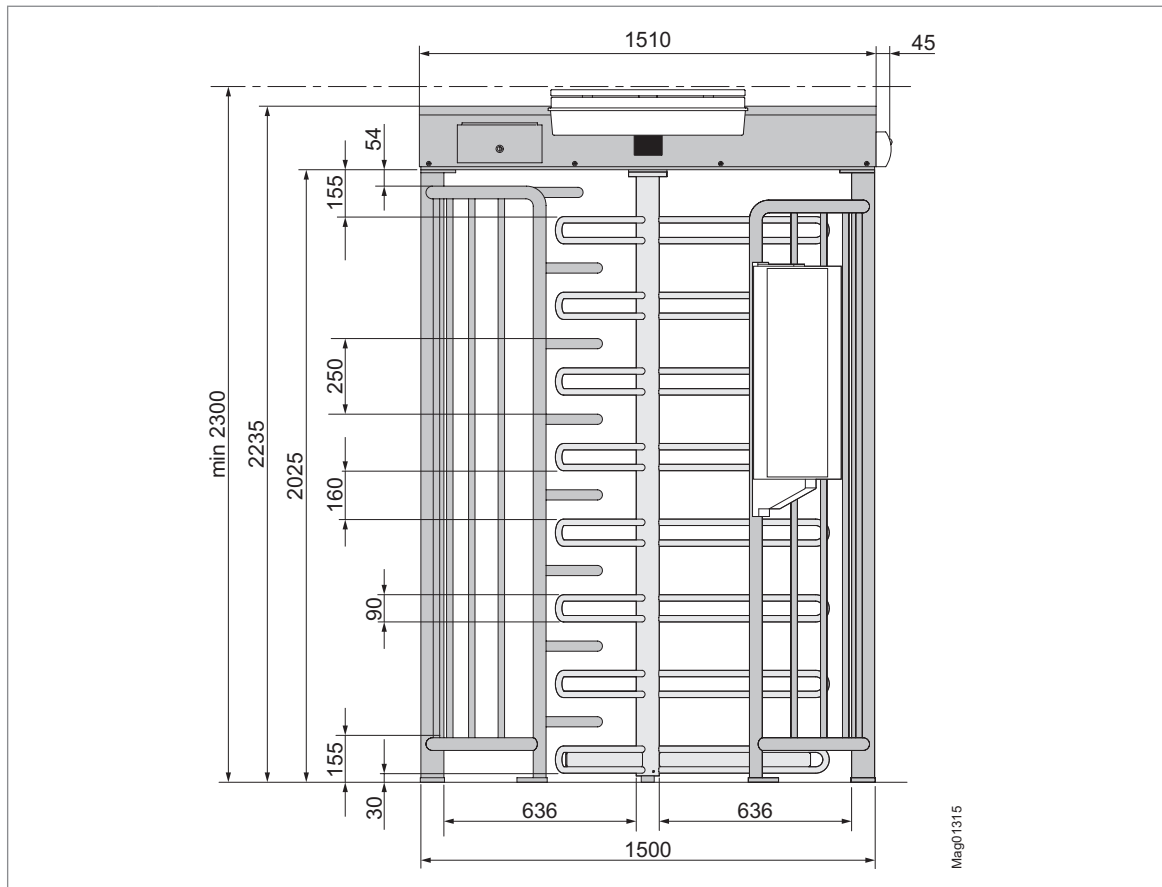

Fig. 6: Dimensions (size in mm) – MPT-333 (3x120°) with option “KHSB”  
View from zone controlled (ZC),  
Version “entrance side left” shown here  
Illumination, twilight switch, GED, and mounting pillars optional  
Required height min. 2300 mm to open the cover.



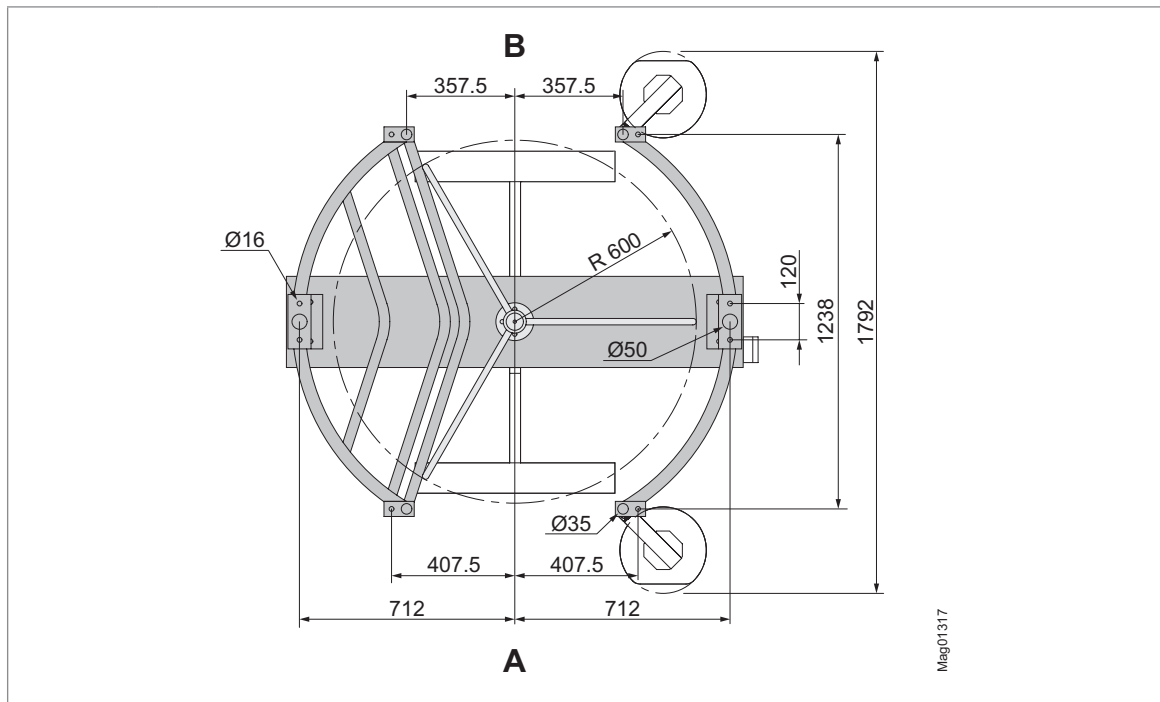

Fig. 8: Dimensions (size in mm) – MPT-333 (3x120°) with option “KHSB”  
 View from below,  
 Version “entrance side left” shown here,  
 Illumination, twilight switch, and mounting pillars optional  
 A Zone not controlled (ZNC)  
 B Zone controlled (ZC)

Designation	Value
Dimensions (width x depth x height)	1510 mm x 1288 mm x 2300 mm
Weight without attachments	250 kg
Material, coating, and colour	Depending on the version ordered: See order confirmation.

Table 4: Dimensions and design – MPT-x3x (3x120°)

## 3.1.3 MPT-333 (4x90°)

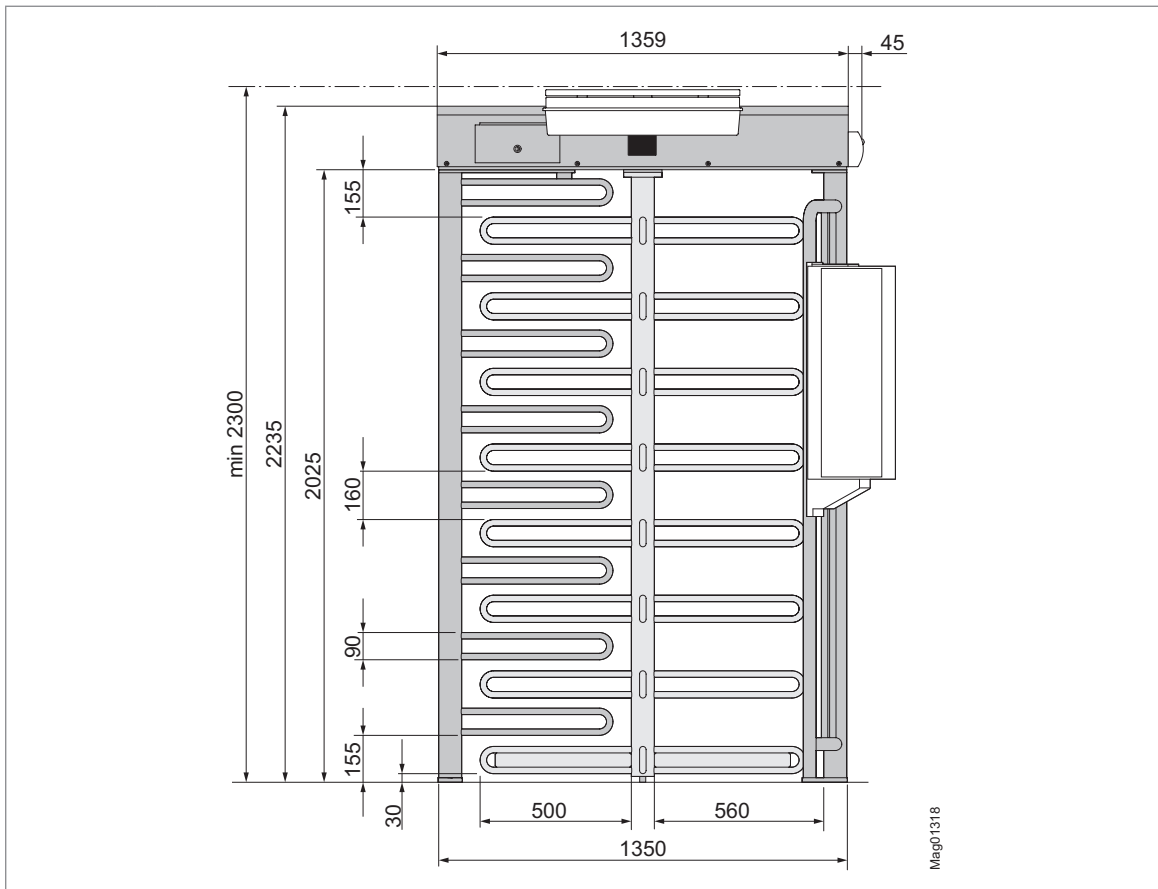

Fig. 9: Dimensions (size in mm) – MPT-333 (4x90°)  
 View from zone controlled (ZC),  
 Version “entrance side left” shown here  
 Illumination, twilight switch, GED. and mounting pillars optional  
 Required height min. 2300 mm to open the cover.



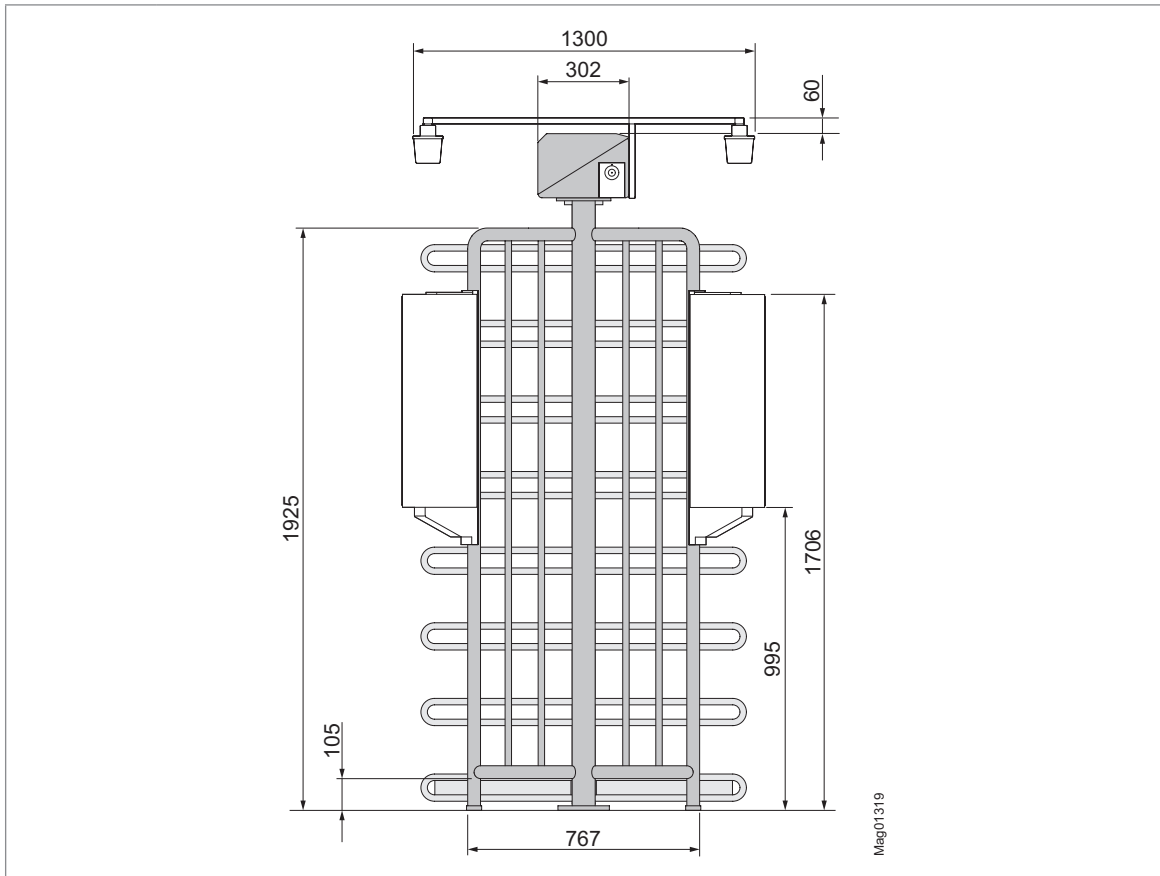

Fig. 10: Dimensions (in mm) – MPT-333 (4x90°)  
Side view,  
Illumination, twilight switch, and mounting pillar optional,  
Dimensions of mounting pillar for version by Magnetic

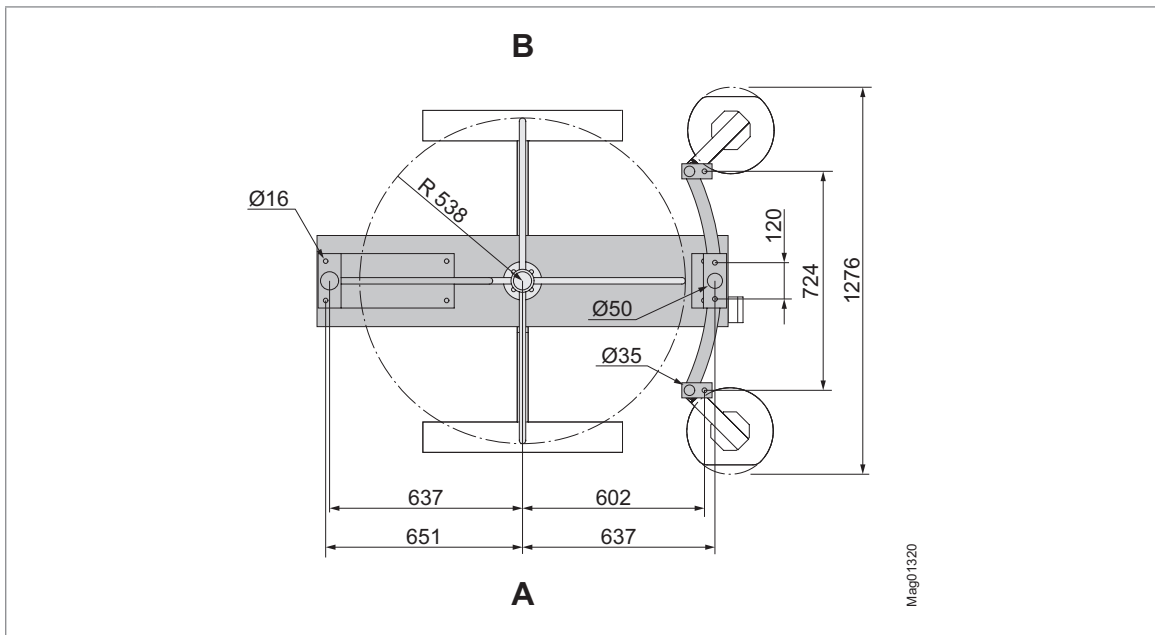

Fig. 11: Dimensions (size in mm) – MPT-333 (4x90°)  
View from below,  
Version “entrance side left” shown here,  
Illumination, twilight switch, and mounting pillars optional

A Zone not controlled (ZNC)

B Zone controlled (ZC)

Designation	Value
Dimensions (width x depth x height)	1359 mm x 1076 mm x 2300 mm
Weight without attachments	250 kg
Material, coating, and colour	Depending on the version ordered: See order confirmation.

Table 5: Dimensions and design – MPT-x3x (4x90°)

### 3.2 Electrical connection

Designation	Value	
	230 V AC / 50 Hz	120 V AC / 60 Hz
Power supply	100 to 240 V AC $\pm$ 10%, 50 to 60 Hz	
Max. current consumption	› In movement: 0.32 A › At home position: 0.22 A	› In movement: 0.4 A › At home position: 0.35 A
Max. power consumption	› In movement: 65 W › At home position: 40 W	› In movement: 45 W › At home position: 40 W
Starting current (max. 30 ms)	19 A	7.5 A
Duty cycle	100%	

Table 6: Electrical connection – MPT-333

### 3.3 Operating conditions

Designation	Value
Operating temperature range	-30 to +55 °C
Storage temperature range	-30 to +70 °C
Relative humidity	Maximum 95%, non-condensing
IP rating	IP 43, optional: IP 54

Table 7: Operating conditions – MPT-3xx

### 3.4 Emissions

Designation	Value
Airborne sound pressure level (LpA)	$\leq$ 70 dB (A)

Table 8: Emissions – MPT

### 3.5 Control unit MGC

Designation		Value
Power supply		24 V DC
Control unit		max. 1 A: max. 300 mA + current consumption of the different plug-in modules
Power consumption		max. 24 W: Max. 7.2 W + power consumption of the individual plug-in modules
Control unit safety device		1 A T
Output terminal 2	Output voltage	24 V DC
	Max. output current	300 mA
Digital inputs	Number	8
	Input voltage	24 ± 10 % V DC
	Input current	< 10 mA per input
	Max. cable length <sup>1)</sup>	30 m
Digital outputs	Number	4 (open collector)
	Input voltage	24 ± 10 % V DC
	Input current	100 mA
	Max. cable length <sup>1)</sup>	30 m
Relay outputs	Number	3 closers + 3 changeovers, isolated
	Max. switched voltage	30 V AC / DC
	Switching current	10 mA up to 1 A
	Max. cable length <sup>1)</sup>	30 m
Display		Graphics display, 128 x 65 pixel
Number of slots for plug-in modules		5

1) Specified without optional over voltage module. For cable lengths above 30 m, over-voltage modules must be installed upstream of the terminals.

Table 9: Control unit MGC

## 4 Design and function

### 4.1 Design

#### 4.1.1 MPT-333 (3x120°)

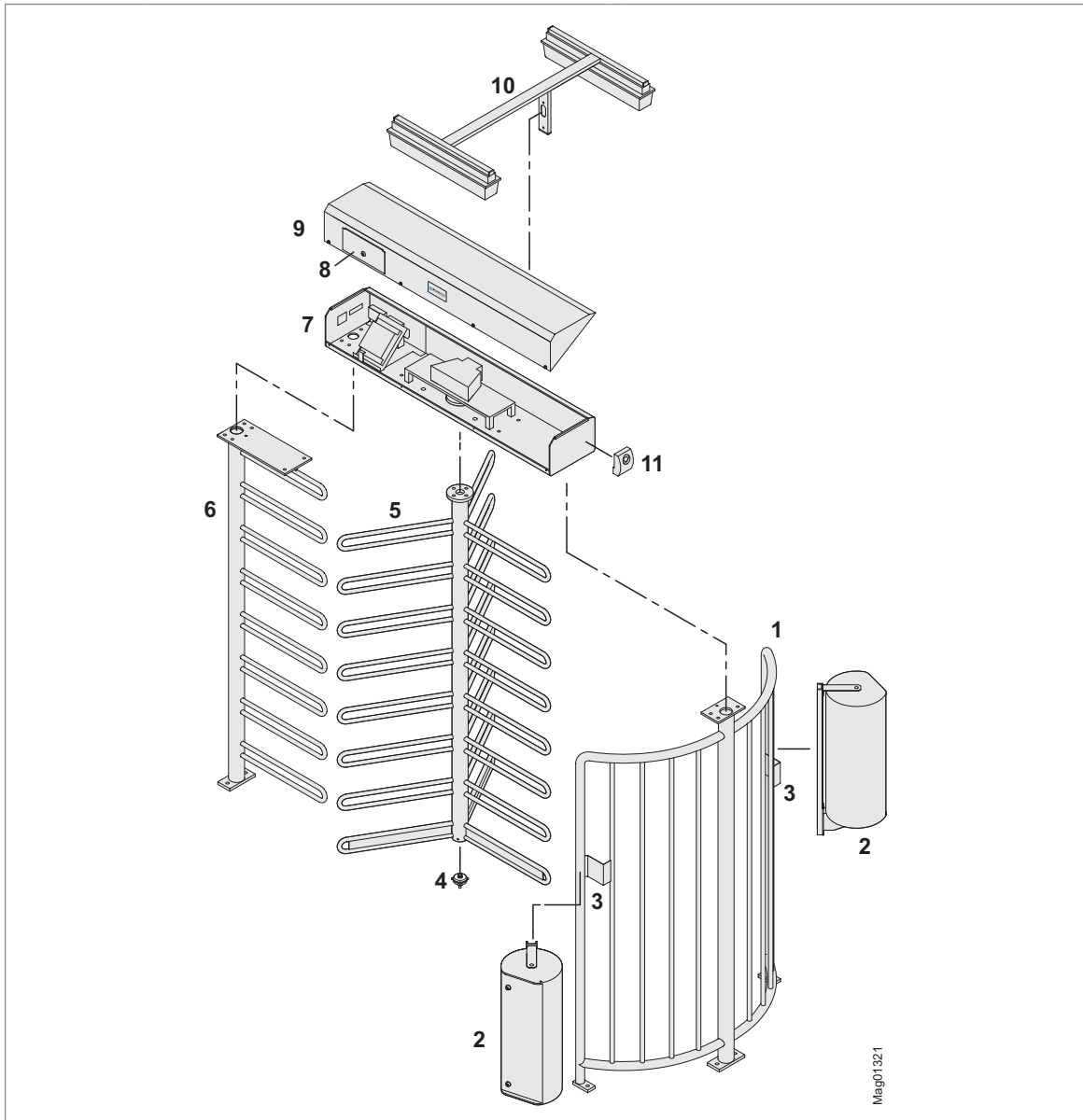

Fig. 12: Design "Full height turnstile MPT-333 (3x120°)"

- |   |   |    |                               |
|---|---|----|-------------------------------|
| 1 | Cage half   | 6  | Locking comb                  |
| 2 | Mounting pillars (optional)                         | 7  | Support beam                  |
| 3 | Mounting bracket e.g., for attachment control units | 8  | Service door                  |
| 4 | Floor bearing                                       | 9  | Cover (without optional GEDs) |
| 5 | Centre pillar                                       | 10 | Illumination (optional)       |
|   |   | 11 | Twilight switch (optional)    |

4.1.2 MPT-333 (3x120°) with “KHSB” option

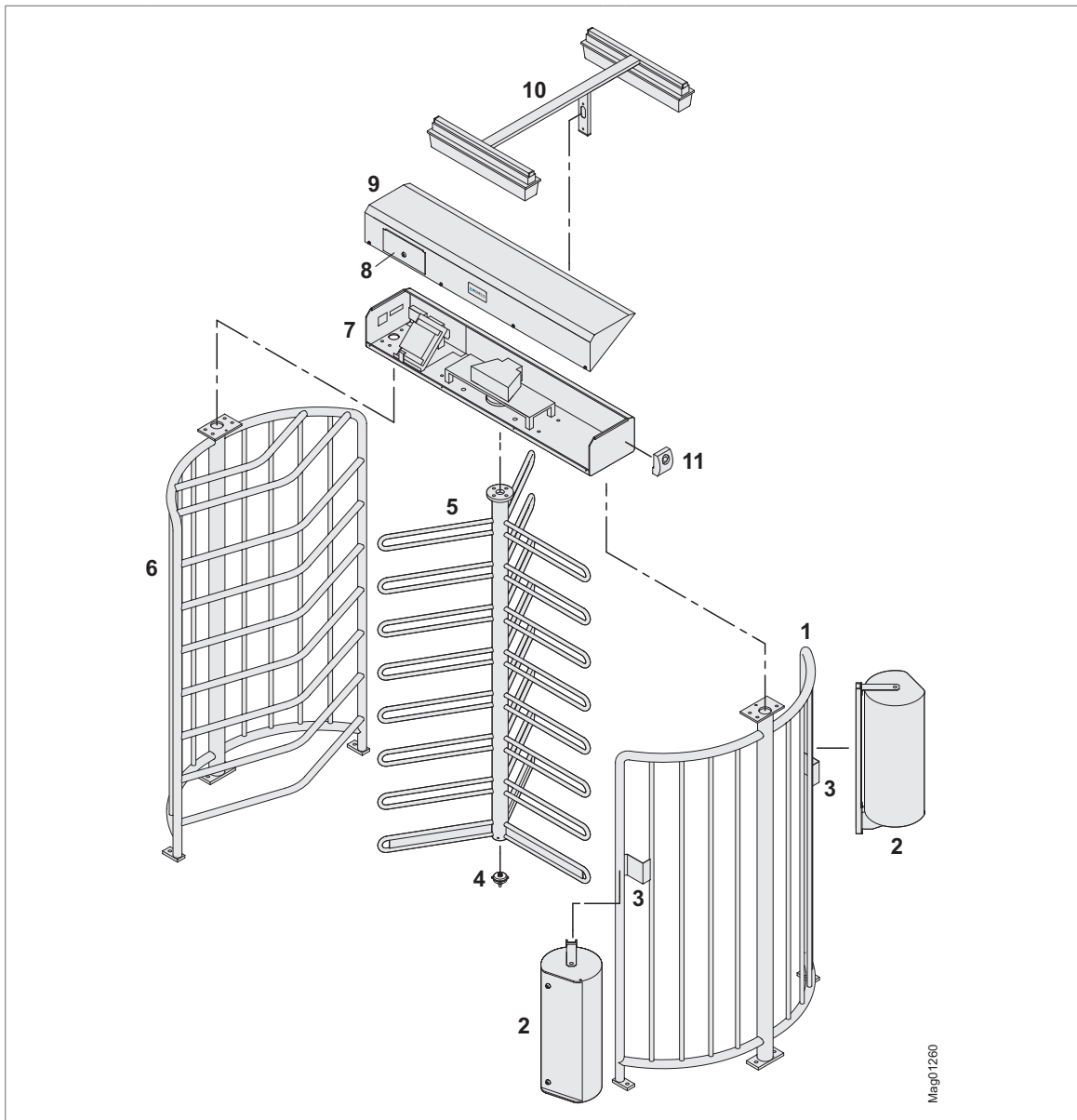

Fig. 13: Setup “Full height turnstile MPT-333 (3x120°)” with option “KHSB”

- |   |  |    |  |
|---|--|----|--|
| 1 | Cage half  | 6  | Cage half with blocking bracket (KHSB) |
| 2 | Mounting pillars (optional)                            | 7  | Support beam                           |
| 3 | Mounting bracket e.g., for attachment<br>control units | 8  | Service door                           |
| 4 | Floor bearing  | 9  | Cover (without optional GEDs)          |
| 5 | Centre pillar  | 10 | Illumination (optional)                |
|   |  | 11 | Twilight switch (optional)             |

4.1.3 MPT-333 (4x90°)

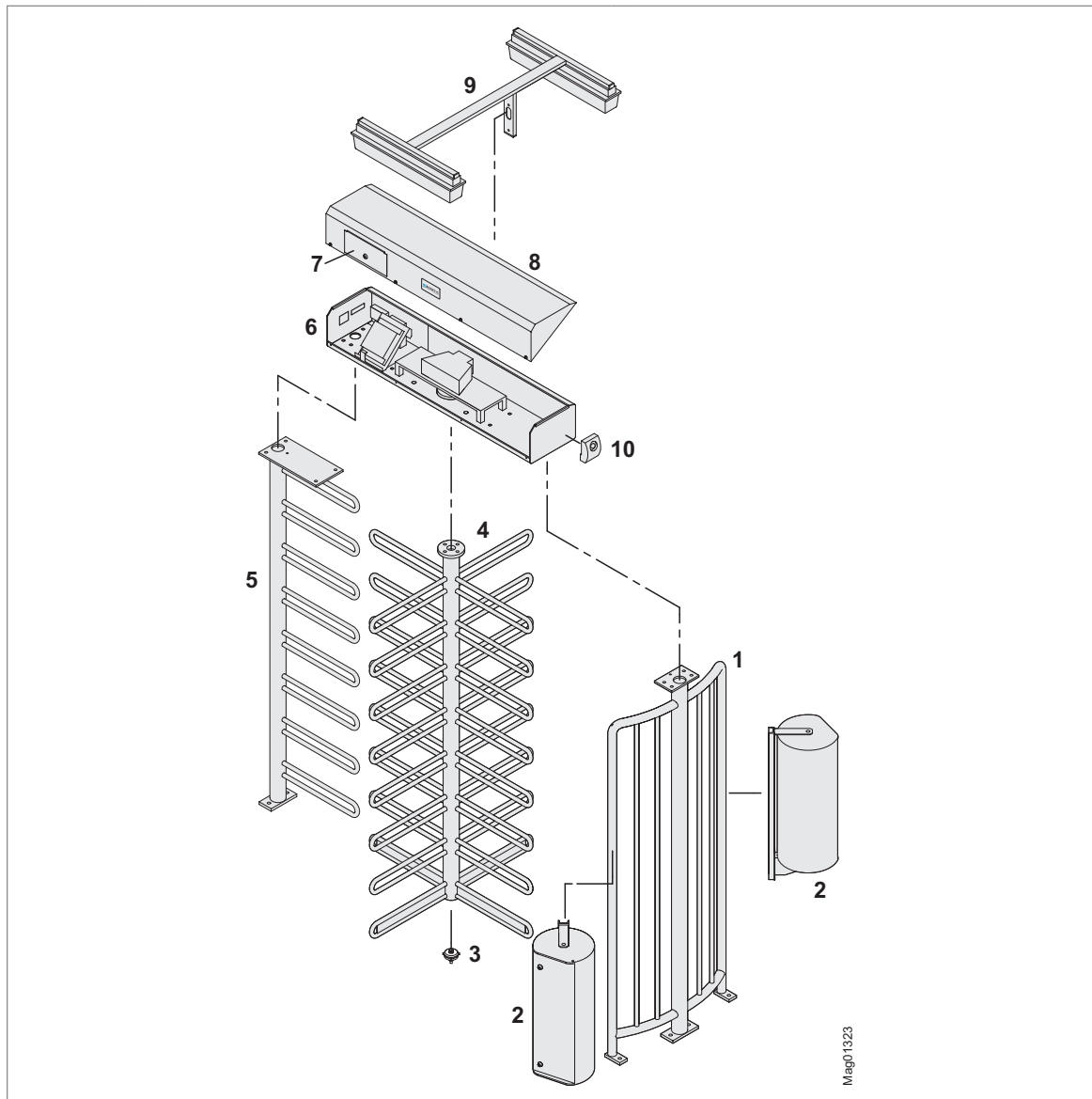

Fig. 14: Structure "Full height turnstile MPT-333 (4x90°)"

- |   |                             |    |                               |
|---|-----------------------------|----|-------------------------------|
| 1 | Cage half                   | 6  | Support beam                  |
| 2 | Mounting pillars (optional) | 7  | Service door                  |
| 3 | Floor bearing               | 8  | Cover (without optional GEDs) |
| 4 | Centre pillar               | 9  | Illumination (optional)       |
| 5 | Locking comb                | 10 | Twilight switch (optional)    |

## **4.2 Function**

The MPT turnstile is used to control pedestrians in outdoor areas with relatively high safety requirements. The turnstile can be operated either in one direction or in both directions.

Normally, the turnstile is closed. Only after validation by means of an external command unit, such as a card reader, will a passage be possible and the centre pillar can be rotated by 120° or 90° depending on the variant. If the centre pillar is not turned completely, a spring moves the centre pillar to the next end position.

Alternatively, the turnstile can be enabled permanently in one direction or in both directions.

As standard, the turnstile is supplied with the “locking rotating freely when de-energised” configuration. In this case, the turnstile can be passed in both directions in the de-energised state. If the turnstile is supplied with the configuration “locking locked when de-energised”, the turnstile is locked in both directions.

A random check function is integrated for checking persons or bags. If the random check function reaches the random value of passages, the passage is blocked and a signal is given. Only after the operating personnel has actuated an enable signal, the passage is enabled and the person can pass.



### 4.3 Definitions and versions

#### Left and right

- › Left: The passage is to the left of the centre pillar.
- › Right: The passage is to the right of the centre pillar.

#### Input and output

The service door or the cover of the support beam points into the zone controlled.

- › Entry: Passage from the zone not controlled (ZNC) to the zone controlled (ZC)
- › Exit: Passage from the zone controlled (ZC) to the zone not controlled (ZNC)

#### Version “Entrance side right”

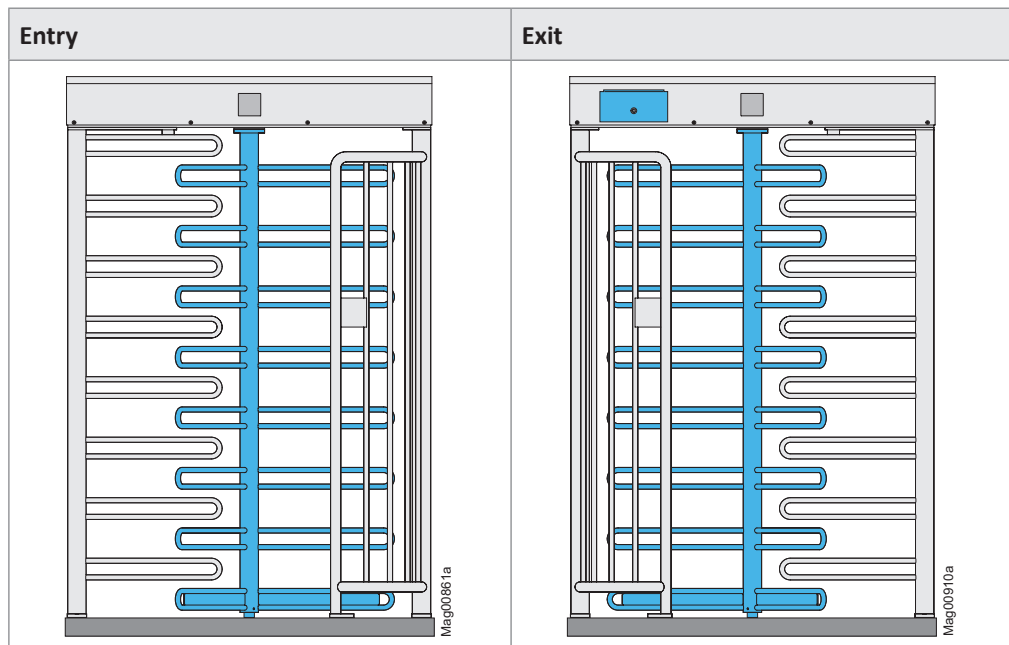

Fig. 15: Version “Entrance side right”, here MPT-x3x 3x120° – view from the zone not controlled (ZNC), the entry is to the right of the centre pillar

Fig. 16: Version “Entrance side right”, here MPT-x3x 3x120° – view from the – zone controlled (ZC), the exit is to the left of the centre pillar

Version "Entrance side left"

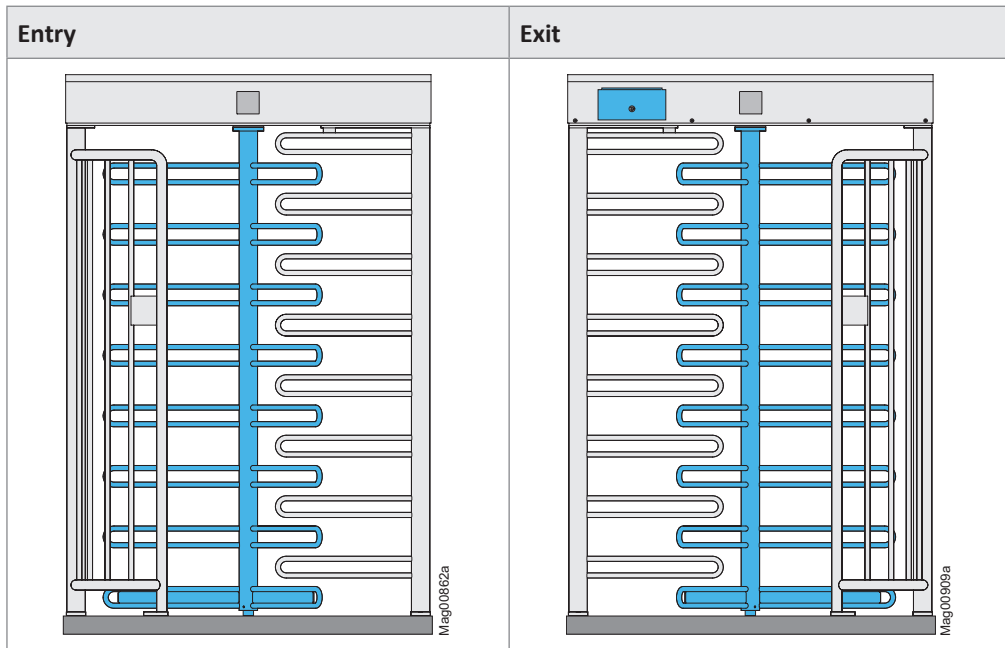

Fig. 17: Version "Entrance side left", here MPT-x3x 3x120° – view from the zone not controlled (ZNC), the entry is to the left of the centre pillar

Fig. 18: Version "Entrance side left", here MPT-x3x 3x120° – view from the – zone controlled (ZC), the exit is to the right of the centre pillar



**IMPORTANT!**

Unless otherwise ordered, the standard version is "Entrance side right".

## 5 Receipt of goods, transport, and storage

### 5.1 Receipt of goods

Immediately check the delivery after receipt for completeness and transport damages.

In case of externally visible transport damage, proceed as follows:

- › Do not accept the delivery or only under reserve.
- › Note the extent of damage on the transport documents or on the delivery note of the carrier.
- › Lodge complaint.



#### IMPORTANT!

Lodge a complaint for each defect as soon as it is recognised. Compensation claims can only be submitted within the valid complaint periods.

---

### 5.2 Safety during transport

#### Qualification of personnel

- › Transport equipment operator
- › Technician

➤ Page 12, chapter 2.3.2.

#### Personal protective equipment

Wear the following personal protective equipment:

- › Work clothes
- › Protective gloves
- › Safety shoes
- › Protective helmet.

**⚠ WARNING****Falling or tipping components!**

The weight of the components can cause serious crushing injuries and severe injuries.

- › Ideally, transport and position the goods to be transported with suitable transport aids such as forklifts or pallet trucks.
- › Forklift forks or lift truck forks must reach entirely through under the components or pallet. Observe the centre of gravity of the load.
- › Secure the transported goods with sufficiently dimensioned lifting gear. Observe the weight of the respective components.
- › Only install the pedestrian gate when there is little or no wind.
- › Secure the components against falling off or tipping.

**⚠ WARNING****Lifting heavy loads!**

Lifting heavy objects can result in severe damage to the back or supporting structure.

- › Transport, lift and set down the goods to be transported using suitable transport aids.

**NOTICE****Improper transport!**

An improper transport may result in damage to the product.

- › Observe the symbols on the packaging.
- › Always load, transport and unload packages carefully.
- › Note the dimension.
- › Do not remove packaging until immediately before mounting and at the final location of the product.

### **5.3 Transport**

The recipient of the product is responsible for internal transport.

- › Transport and position the goods to be transported with a suitable forklift or pallet truck.
- › The forklift forks or lift truck forks must reach completely under the transported goods. Observe the centre of gravity of the load.
- › Secure the transported goods with sufficiently dimensioned lifting gear.

### **5.4 Storage**



Store packages or the product under the following conditions:



- › Store the delivery in its original packaging. Observe the symbols on the packaging.
- › Do not store outdoors.
- › Store dry and dust free.
- › Do not expose to aggressive media.
- › Protect against solar irradiation.
- › Avoid mechanical vibrations.
- › Storage temperature range: –30 to +70 °C
- › Relative humidity: max. 95%, non-condensing

Check the general condition of all components and packaging regularly if they are stored for longer periods than 3 months.

## 6 Unpacking, scope of delivery and identification

### 6.1 Unpacking

 <b>WARNING</b>	
	<p><b>Falling or tipping components!</b></p> <p>The weight of the components can cause serious crushing injuries and severe injuries.</p> <ul style="list-style-type: none"> <li>› Ideally, transport and position the goods to be transported with suitable transport aids such as forklifts or pallet trucks.</li> <li>› Forklift forks or lift truck forks must reach entirely through under the components or pallet. Observe the centre of gravity of the load.</li> <li>› Secure the transported goods with sufficiently dimensioned lifting gear. Observe the weight of the respective components.</li> <li>› Only install the pedestrian gate when there is little or no wind.</li> <li>› Secure the components against falling off or tipping.</li> </ul>

 <b>WARNING</b>	
	<p><b>Lifting heavy loads!</b></p> <p>Lifting heavy objects can result in severe damage to the back or supporting structure.</p> <ul style="list-style-type: none"> <li>› Transport, lift and set down the goods to be transported using suitable transport aids.</li> </ul>

The individual components are packed according to the expected transport conditions.

Do not destroy the packaging and remove only directly before mounting. The packaging should protect the components against transport damages, corrosion, etc.

1. Unpack product at final location.
2. Report an incomplete or faulty delivery to Magnetic.
3. Check the scope of delivery with the delivery note.
4. Sort materials by type and size and continue to use them after recycling. Observe local and regional standard laws and guidelines.

## 6.2 Scope of delivery

For version, options, and attachments, see your order confirmation.

The following components are supplied for each MPT turnstile by default:

- › 1 centre pillar
- › 1 cage half
- › 1 locking comb or with option “KHSB” a second cage half with blocking bracket
- › 1 support beam with mounted cover
- › 1 floor bearing for the centre pillar
- › Attachment material for mounting the turnstile directly on a foundation or on a base frame
- › 1 drilling template
- › 2 keys for the service door
- › Associated documentation and wiring diagram



### IMPORTANT!

Information about the attachment material: ↗ [Page 42, chapter 7.2](#)

---

## 6.3 Identification

### 6.3.1 Type plate

The type plate is located below the hood.

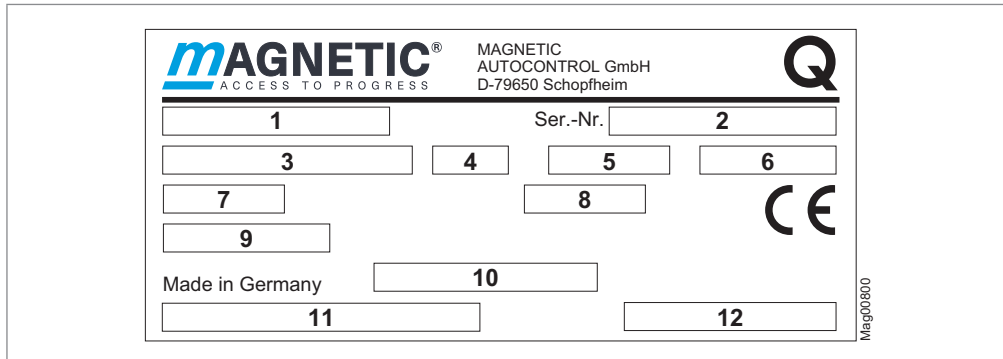

Fig. 19: Type plate

- 1 Product designation
- 2 Serial number
- 3 Power supply
- 4 Frequency
- 5 Current consumption
- 6 Power consumption
- 7 IP rating
- 8 Duty cycle for operating mode S1 "Continuous operation"
- 9 Ambient temperature range
- 10 Date of manufacture, version, date of type plate printing
- 11 Bar code for product designation
- 12 Bar code for serial number



## 7 Mounting

### 7.1 Safety during mounting

#### Qualification of personnel

- › Technician
- › Qualified electrician
- ↗ Page 12, chapter 2.3.2.

#### Personal protective equipment

Wear the following personal protective equipment:

- › Work clothes
- › Protective gloves
- › Safety shoes
- › Protective helmet.

#### WARNING



##### **Improper attachment!**

Improper attachment can cause the pedestrian gate to tip over, resulting in crushing and serious injury.

- › Mount the pedestrian gate in accordance with the description on the foundation.
- › Observe and follow separate notices and instructions provided by the manufacturer of the attachment material.
- › After mounting, check all screws and nuts for tightness.

#### WARNING



##### **Improper mounting on flammable ground!**

The mounting of the pedestrian gate on a flammable floor can promote the development of a fire and accelerate the spread of the fire. A fire and the resulting smoke can cause life-threatening injuries.

- › Only mount the pedestrian gate on a non-flammable floor.

**WARNING****Lifting heavy loads!**

The weight of heavy objects can severely injure a person's back or supportive system.

- › Transport, lift and set down the goods to be transported using suitable transport aids.

**NOTICE****Possible seizure of stainless steel fasteners!**

Stainless steel fasteners are susceptible to seizure.

- › Grease stainless steel screws before use.

**7.2 Mounting options and notices, attachment material****7.2.1 Overview**

You may mount the MPT pedestrian gate as follows:

- › Directly on the foundation
- › Via an optional base frame

**7.2.2 Directly on the foundation**

In this variant, mount the pedestrian gate on a foundation using foundation anchors.

If you choose this variant, we recommend the ARS alignment templates. The alignment templates specify the required drill hole distances.

More information: [Planning documentation perimeter products](#)

**Attachment material**

The attachment material for mounting the pedestrian gate directly on a foundation is included in the scope of delivery.

### 7.2.3 Optional base frame

In this variant, mount the base frame on a foundation using foundation anchors. Install the MPT pedestrian gate on the base frame.



#### IMPORTANT!

We recommend this variant because the mounting distances are specified by the base frame. This variant must be chosen for use on interlocking stone paving and cobblestones.

#### Attachment material

The attachment material for mounting the pedestrian gate on a base frame is included in the scope of delivery.

The attachment material for the base frame is included in the scope of delivery of the base frame. The base frame must be ordered separately.

More information: [Planning documentation perimeter products](#)

## 7.3 Required steps

The following work steps must be carried out before mounting:

- › Specify the mounting position. ↗ [Page 44, chapter 7.4.](#)
- › Set up foundation and placing empty conduits. ↗ [Page 44, chapter 7.5.](#)
- › Set sleeves with inner thread. ↗ [Page 50, chapter 7.6.](#)

The following work steps must be performed during mounting:

- › Unpack the pedestrian gate. ↗ [Page 38, chapter 6.1.](#)
- › Mount the pedestrian gate.
  - › MPT-333 (3x120°): ↗ [Page 51, chapter 7.7.](#)
  - › MPT-333 (4x90°): ↗ [Page 66, chapter 7.8.](#)
- › Mount optional mounting pillar for access-control devices. ↗ [Page 79, chapter 8.](#)
- › Connect the pedestrian gate electrically. ↗ [Page 87, chapter 9.](#)
- › Mount and connect access-control devices. ↗ [Page 94, chapter 9.7.](#)

## 7.4 Specifying the mounting position

The pedestrian gate can be supplied in the following versions: “Entrance side right” and “Entrance side left”. ↗ Page 33, chapter 4.3.

The layout of the components depends on the version ordered. The service door in the support beam should point towards the zone controlled.

## 7.5 Building the foundation and laying empty conduits

### 7.5.1 Foundation requirements

The foundation must meet the following requirements:

- › Have sufficient load-carrying capacity
- › Concrete C20/25 or corresponding industrial floor
- › Fastening must have a secure grip
- › Foundation cross-section according to foundation and empty conduit plan
- › Non-slip surface
- › Horizontal and level.

Foundation and empty conduit plans:

- › MPT-333 (3x120°): ↗ Page 47, chapter 7.5.4
- › MPT-333 (3x120°) with option “KHSB”: ↗ Page 48, chapter 7.5.5
- › MPT-333 (4x90°): ↗ Page 49, chapter 7.5.6

When installing outdoors, the foundation must meet the following additional requirements:

- › Concrete C35/45 XD 3 XF2 with reinforcement
- › Foundation depth: at least 800 mm, frost-proof.  
Adjust the foundation depth to the local conditions.

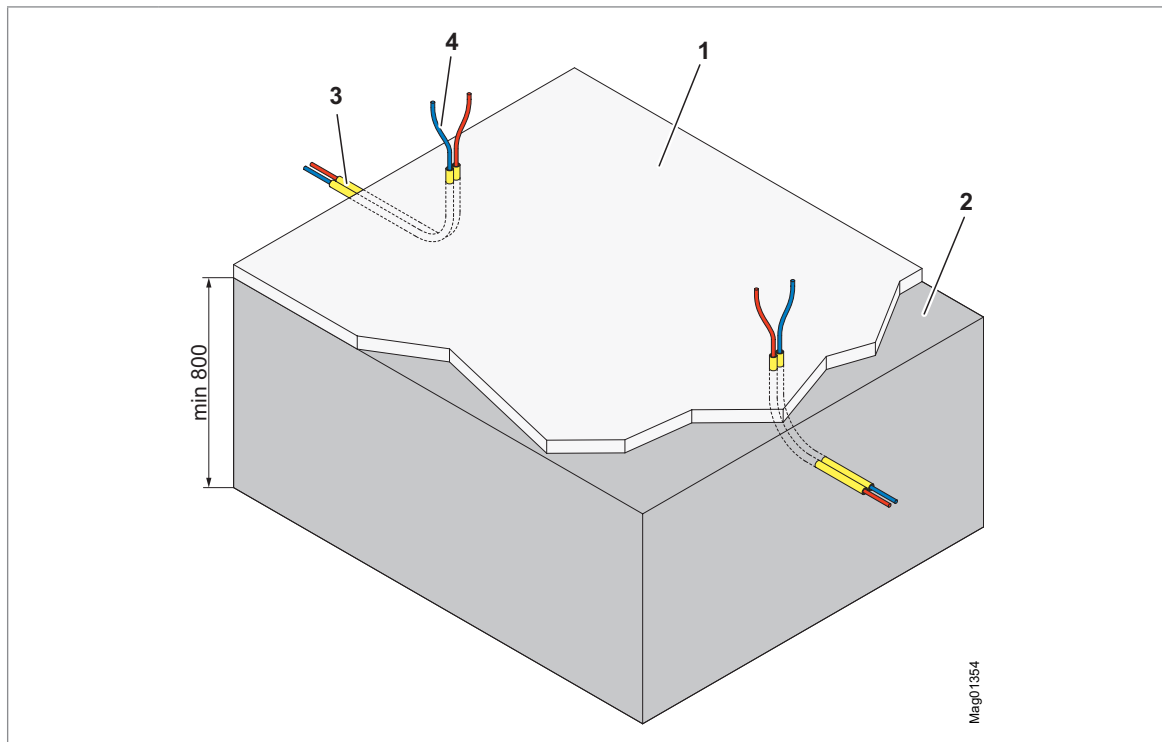

Fig. 20: Example of foundation design with empty tubes (size in mm)

- 1 Finished covering / smooth coating level and horizontal
- 2 Foundation C35/45 XD3 XF2 with reinforcement, foundation depth: at least 800 mm, frost-proof
- 3 Lay empty conduits separately for mains cable and control lines. Leave empty conduits 50 mm above the foundation. See the corresponding foundation and empty conduit plan for possible positions of empty conduits.
- 4 Have lines overlapping for at least 5 m of the conduits.

### 7.5.2 Empty conduits requirements

Note the following points for the empty conduits:

- › Lay empty conduits according to the foundation plan.
- › Conduits have to be planned to a sufficient length.
- › Plan the empty conduits required for access control-devices and other peripheral equipment. The wiring for this is the responsibility of the customer.



#### IMPORTANT!

To warrant trouble-free operation, individual empty conduits must be installed for all mains cables and control lines.

---

Foundation and empty conduit plans:

- › MPT-333 (3x120°): ↗ Page 47, chapter 7.5.4
- › MPT-333 (3x120°) with option “KHSB”: ↗ Page 48, chapter 7.5.5
- › MPT-333 (4x90°): ↗ Page 49, chapter 7.5.6

### 7.5.3 Building the foundation and laying empty conduits

1. Excavate the foundation hole according to the foundation and empty conduit plan.
2. Place empty conduits according to the foundation and empty conduit plan in the foundation hole.
3. Seal empty conduits so that no water can enter.
4. Concrete the foundation.
5. Create a smooth plaster.
6. Let concrete cure.
7. Apply moisture protection for outdoor mounting.

Foundation and empty conduit plans:

- › MPT-333 (3x120°): ↗ Page 47, chapter 7.5.4
- › MPT-333 (3x120°) with option “KHSB”: ↗ Page 48, chapter 7.5.5
- › MPT-333 (4x90°): ↗ Page 49, chapter 7.5.6

#### 7.5.4 Foundation and empty conduit plan MPT-333 (3x120°)

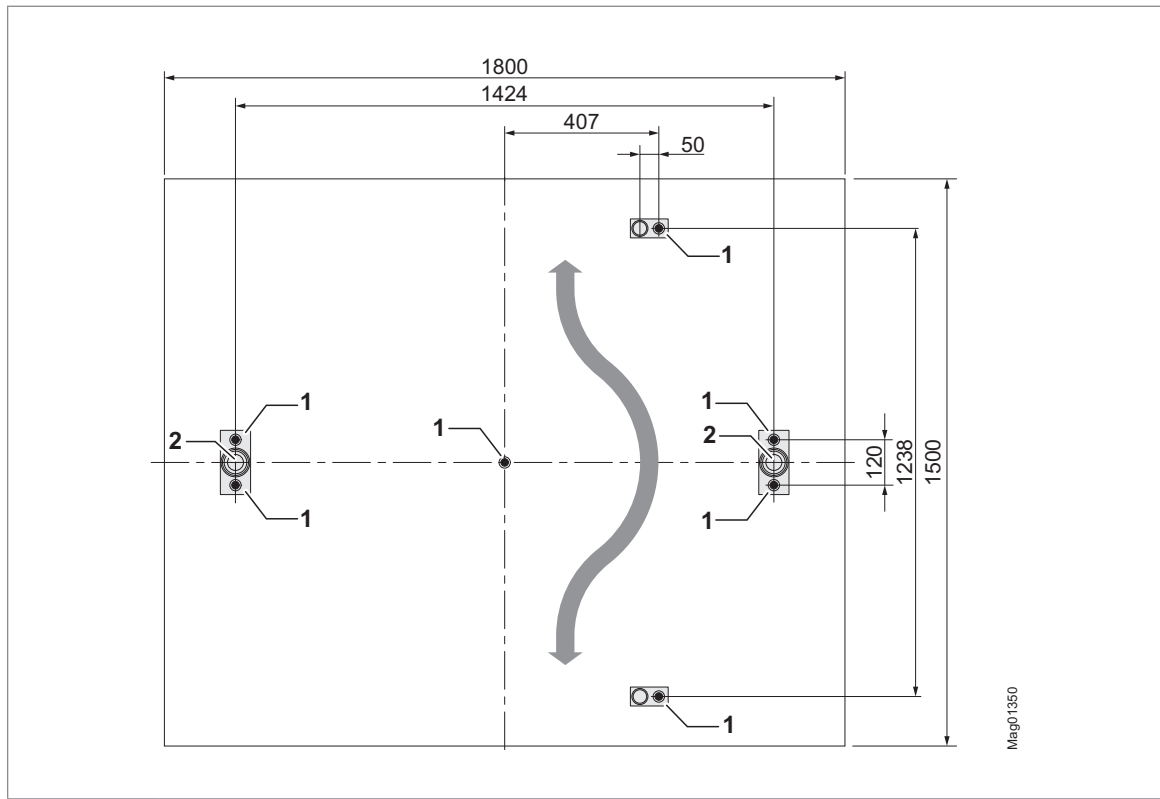

Fig. 21: Foundation and empty conduit plan MPT-333 (3x120°) for direct mounting on a foundation

- 1 Bores for sleeves with inner thread (7 pieces), bores for sleeves with inner thread depending on make:  
Upat UKA 3 M10: Drilling diameter 16 mm, drilling depth 90 mm;  
Fischer RG 16 x 90 M10: Drilling diameter 18 mm, drilling depth 90 mm.  
Follow separate instructions for sleeves with inner thread.
- 2 Possible position for empty conduits. Lay empty conduits separately for mains cable and control lines. Allow empty conduits to protrude approx. 50 mm above foundation and lines to protrude at least 5 m from the empty conduits.

**7.5.5 Foundation and empty pipe plan MPT-333 (3x120°) with “KHSB” option**

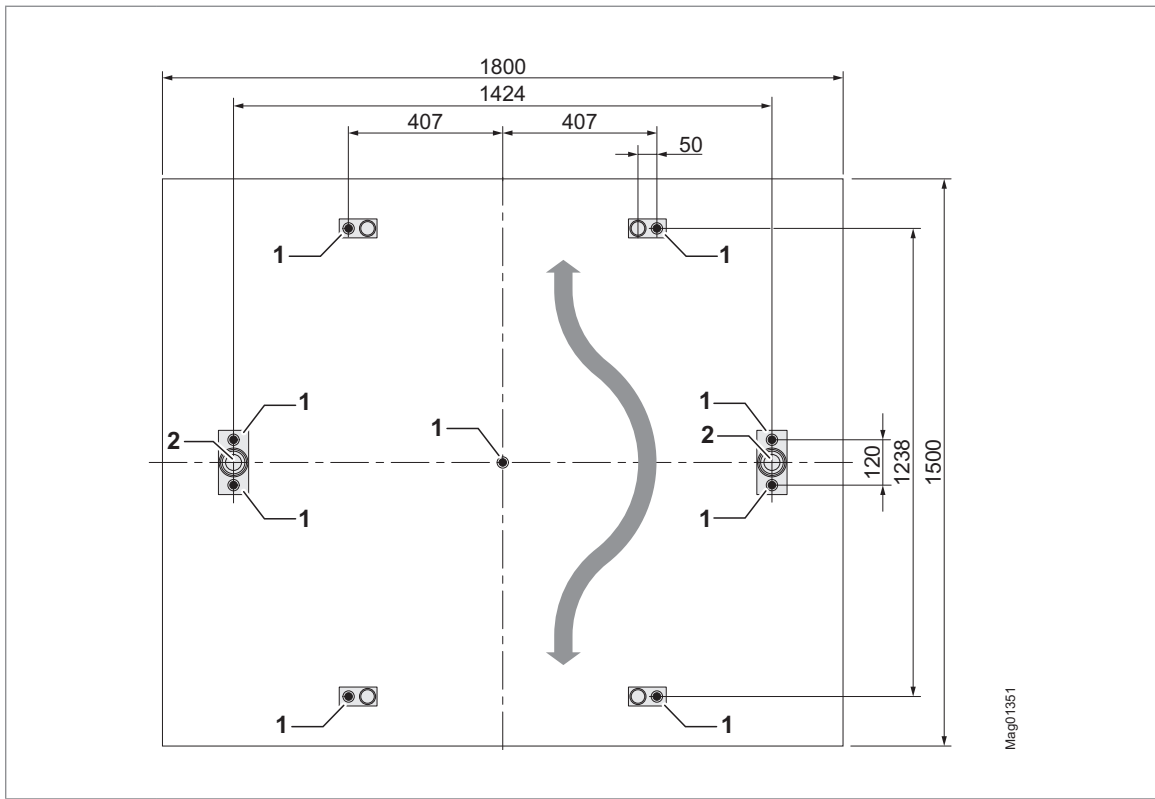

Fig. 22: Foundation and empty conduit plan MPT-333 (3x120°) with option “KHSB” for direct mounting on a foundation

- 1 Bores for sleeves with inner thread (9 pieces):  
 Bores for sleeves with inner thread depending on make:  
 Upat UKA 3 M10: Drilling diameter 16 mm, drilling depth 90 mm;  
 Fischer RG 16 x 90 M10: Drilling diameter 18 mm, drilling depth 90 mm.  
 Follow separate instructions for sleeves with inner thread.
- 2 Possible position for empty conduits. Lay empty conduits separately for mains cable and control lines. Allow empty conduits to protrude approx. 50 mm above foundation and lines to protrude at least 5 m from the empty conduits.



### 7.5.6 Foundation and empty conduit plan MPT-333 (4x90°)

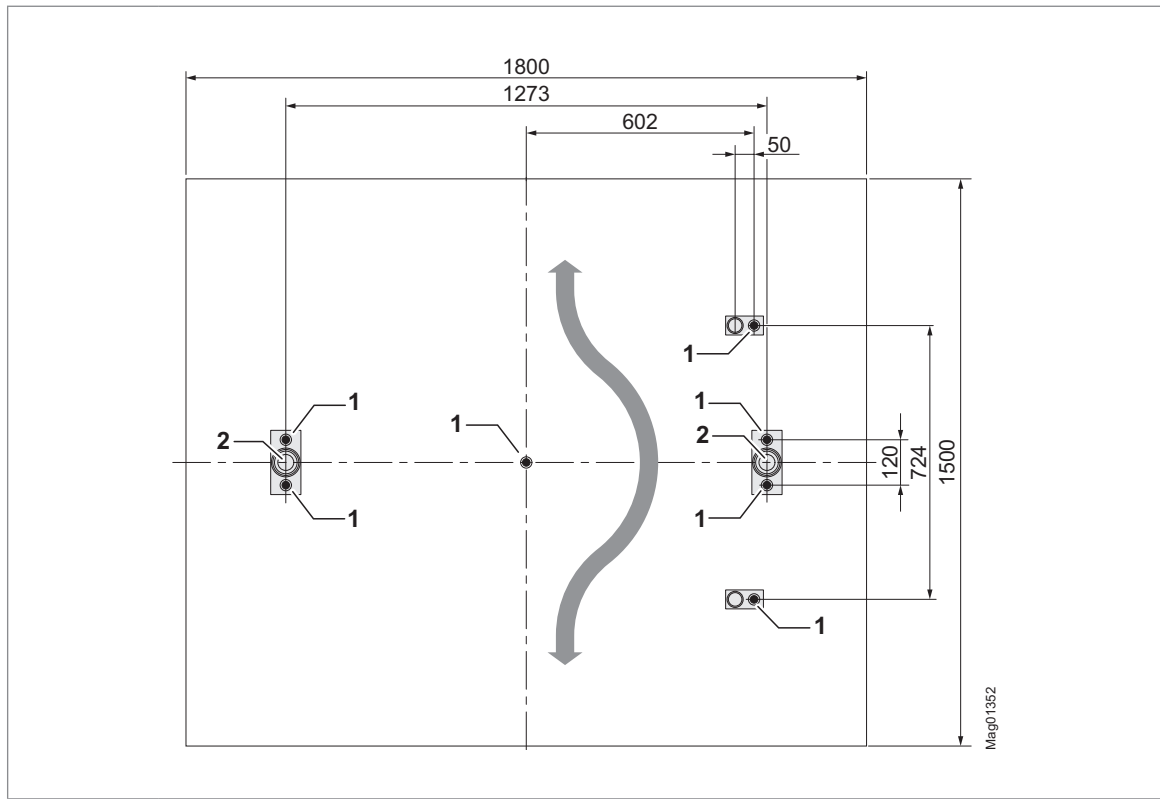

Fig. 23: Foundation and empty conduit plan MPT-333 (4x90°) for direct mounting on a foundation

- 1 Bores for sleeves with inner thread (7 pieces), bores for sleeves with inner thread depending on make:  
Upat UKA 3 M10: Drilling diameter 16 mm, drilling depth 90 mm;  
Fischer RG 16 x 90 M10: Drilling diameter 18 mm, drilling depth 90 mm.  
Follow separate instructions for sleeves with inner thread.
- 2 Possible position for empty conduits. Lay empty conduits separately for mains cable and control lines. Allow empty conduits to protrude approx. 50 mm above foundation and lines to protrude at least 5 m from the empty conduits.

## 7.6 Preliminary work for mounting directly on the foundation

### Requirements

- › The conduits have been placed.
- › The foundation has cured.



### IMPORTANT!

Observe the separate instructions as well as the packaging inscriptions for the attachment material.

---

1. Mark holes for sleeve with inner thread.
  2. Drill the boreholes for the sleeves with inner thread according to the foundation plan.
    - › MPT-333 (3x120°): ↗ Page 47, chapter 7.5.4
    - › MPT-333 (3x120°) with option “KHSB”: ↗ Page 48, chapter 7.5.5
    - › MPT-333 (4x90°): ↗ Page 49, chapter 7.5.6
  3. Clean the boreholes with compressed air.
  4. Inject injection mortar into the boreholes.
  5. Screw in the sleeve with inner thread by hand until the upper edge of the sleeve with inner thread is flush with the upper edge of the foundation.
  6. Wait for the curing time. Follow separate instructions.
- ✓ The preliminary work has been completed. You can mount the components of the pedestrian gate.

## 7.7 Mounting the MPT-333 (3x120°) without and with option “KHSB”

The mounting of the pedestrian gate on a base frame and the mounting of the pedestrian gate directly on a foundation are identical in procedure. Only the attachment material is partly different. The following illustrations show the installation directly on a foundation.

The MPT-333 pedestrian gate is supplied with a locking comb as standard. Alternatively, you can order the pedestrian gate with the “KHSB” option. With the “KHSB” option, a cage half with blocking bracket is mounted instead of the locking comb. Mounting of the other components is identical.

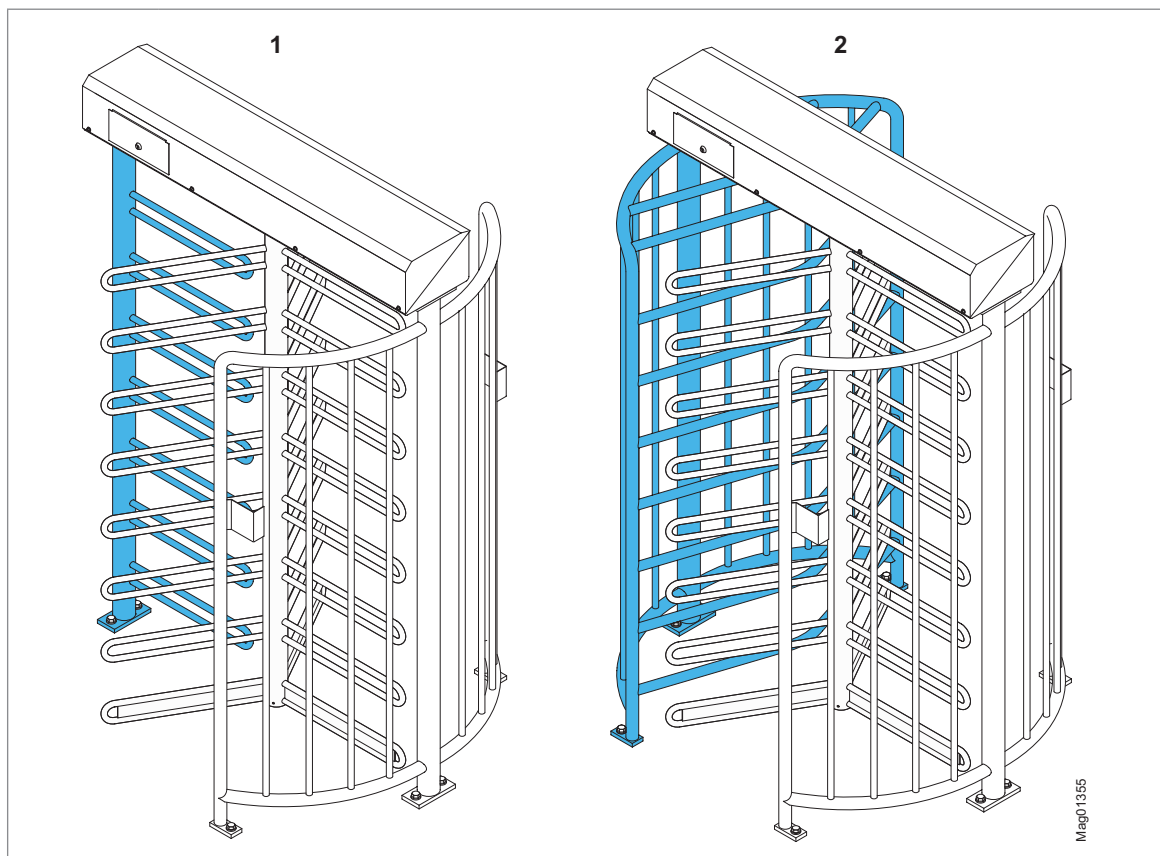

Fig. 24: Variants MPT-333 (3x120°)

- 1 Standard version with locking comb
- 2 Variant with cage half with blocking bracket (option “KHSB”)

### 7.7.1 Mounting the locking comb or option "KHSB" MPT-333 (3x120°)

#### Mounting the locking comb

1. Pull the mains cable and control lines through the support of the locking comb. Alternatively, you can also pull the cables through the support of the cage half.
2. Mount the locking comb.

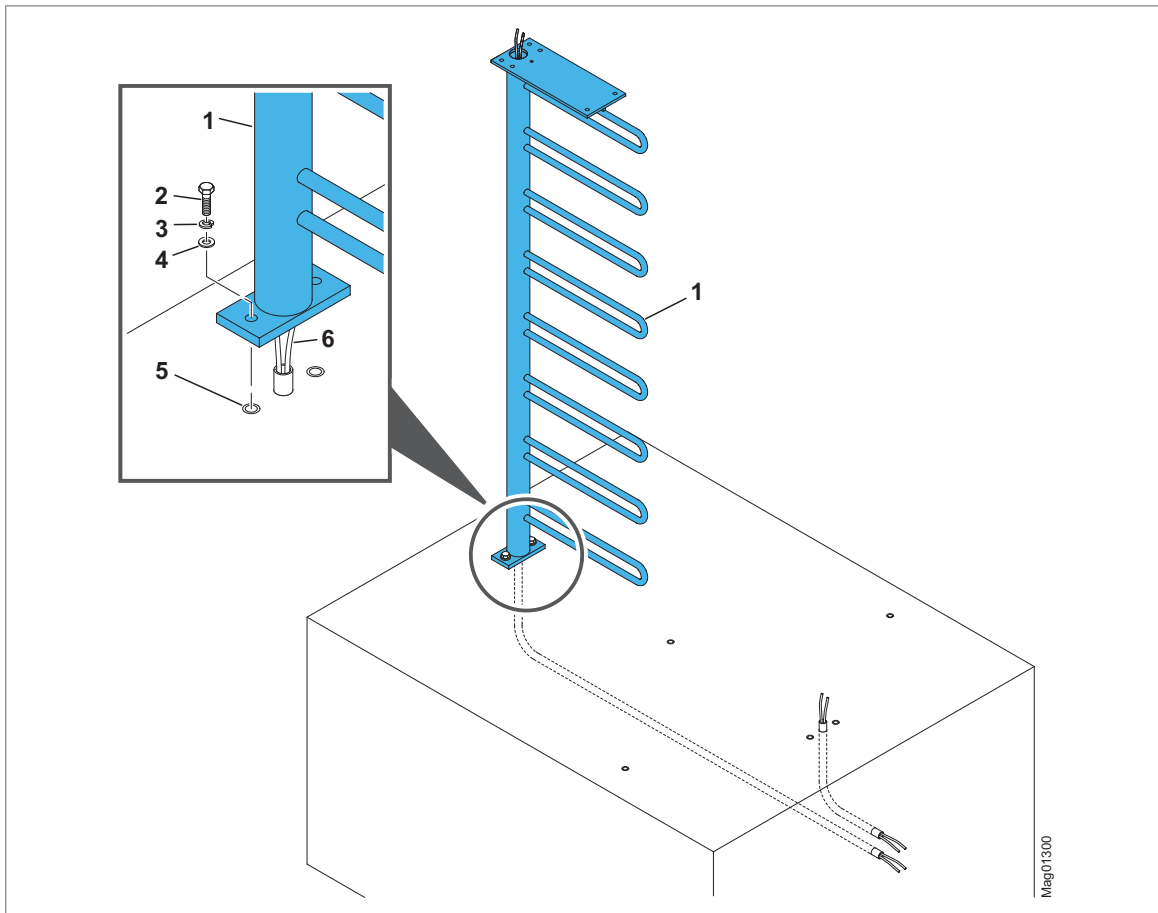

Fig. 25: Mounting the locking comb – MPT-333 (3x120°)

- 1 Locking comb
- 2 Hexagon head screw M10 x 35
- 3 Spring washer
- 4 Washer D10.5
- 5 Bore with sleeve with inner thread
- 6 Mains cable and control lines (example)

**Mounting the cage half with blocking bracket (option "KHSB")**

1. Pull the mains cable and control lines through the support of the cage half with blocking bracket. Alternatively, you can also pull the cables through the support of the standard cage half.
2. Mount the cage half with blocking bracket.

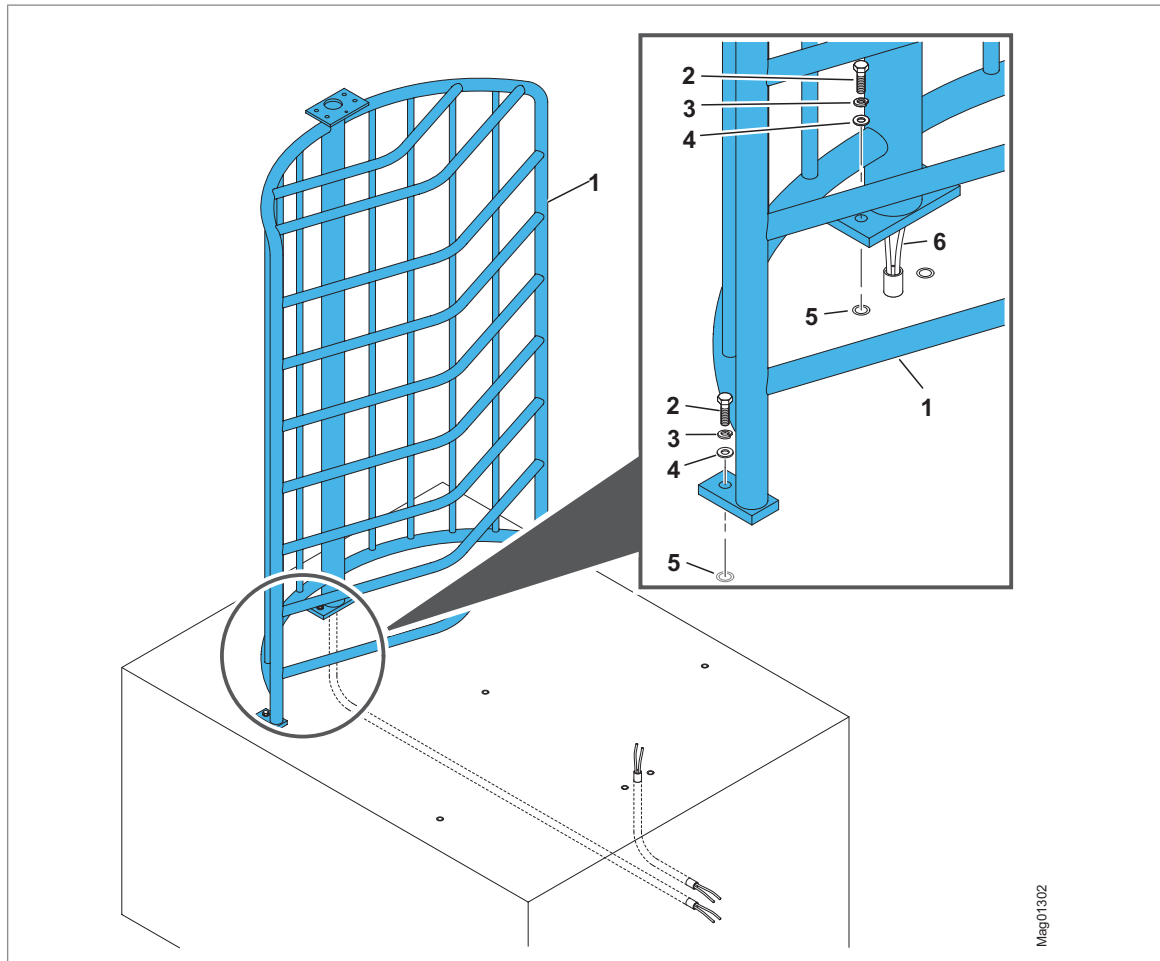

Fig. 26: Mounting the cage half with blocking bracket (option "KHSB")

- 1 Cage half with blocking bracket (option "KHSB")
- 2 Hexagon head screw M10 x 35
- 3 Spring washer
- 4 Washer D10.5
- 5 Bore with sleeve with inner thread
- 6 Mains cable and control lines (example)

### 7.7.2 Mounting the cage half MPT-333 (3x120°)

1. Mount the cage half. If necessary, pull lines through the support.

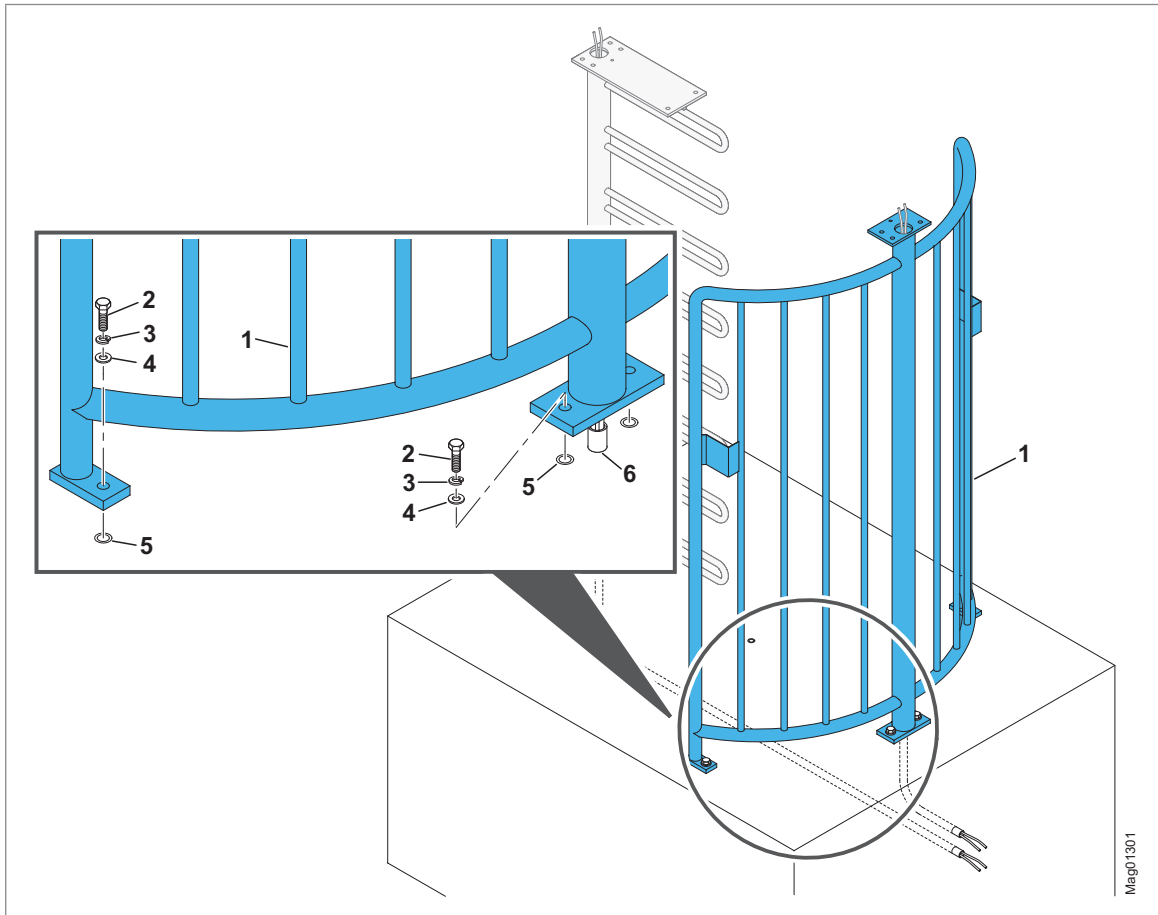

Fig. 27: Mounting the cage half – MPT-333 (3x120°)

- 1 Cage half (standard)
- 2 Hexagon head screw M10 x 35
- 3 Spring washer
- 4 Washer D10.5
- 5 Bores for sleeves with inner thread
- 6 Mains cable and control lines (alternative)

### 7.7.3 Mounting the support beam MPT-333 (3x120°)

The support beam is delivered with the cover closed. The service door and the cover must be removed and the protective earth conductors for the service door and for the cover must be disconnected for mounting.

1. Open the service door with the supplied key.
2. Disconnect the protective earth conductor for the service door at the earthing point for the cover.
3. Put the service door aside.
4. Disconnect the protective earth conductor for the cover at the earthing point for the cover.

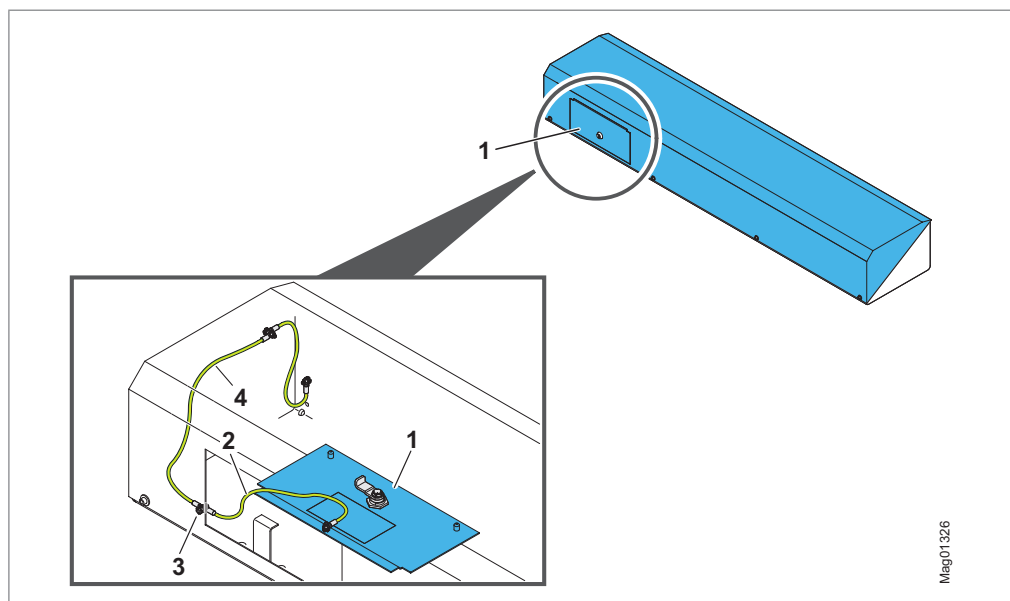

Fig. 28: Disconnect the protective earth conductor from the service door and cover (exemplary representation)

- 1 Service door
- 2 Protective earth conductor for service door
- 3 Hood earthing point
- 4 Protective earth conductor for cover

5. Loosen the screw of the cover.
6. Pull the cover to the front and remove it.

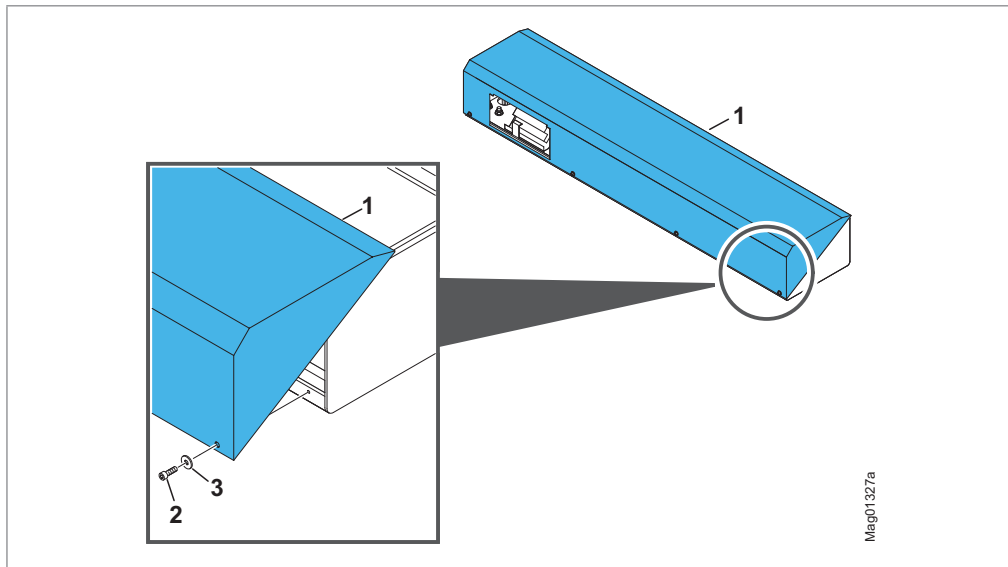

Fig. 29: Opening the cover

- 1 Cover
- 2 Screw
- 3 Washer

7. Prepare the support beams for assembly. For example, place support beams on the forks of a forklift truck. Secure the support beams against slipping, e.g., with screw clamps on the forks.

**⚠ WARNING**

Risk of injury from a falling support beam!

8. Place the support beam on the cage half and on the locking comb. At the same time, pull the lines through the bores in the bottom of the support beam.
9. Immediately secure the support beam using the countersunk screws supplied. Tighten the countersunk screws.
10. Ground the support beam on both sides using the contact disc and the hexagon head screws supplied.
11. Mount the tension relief on the support beam.



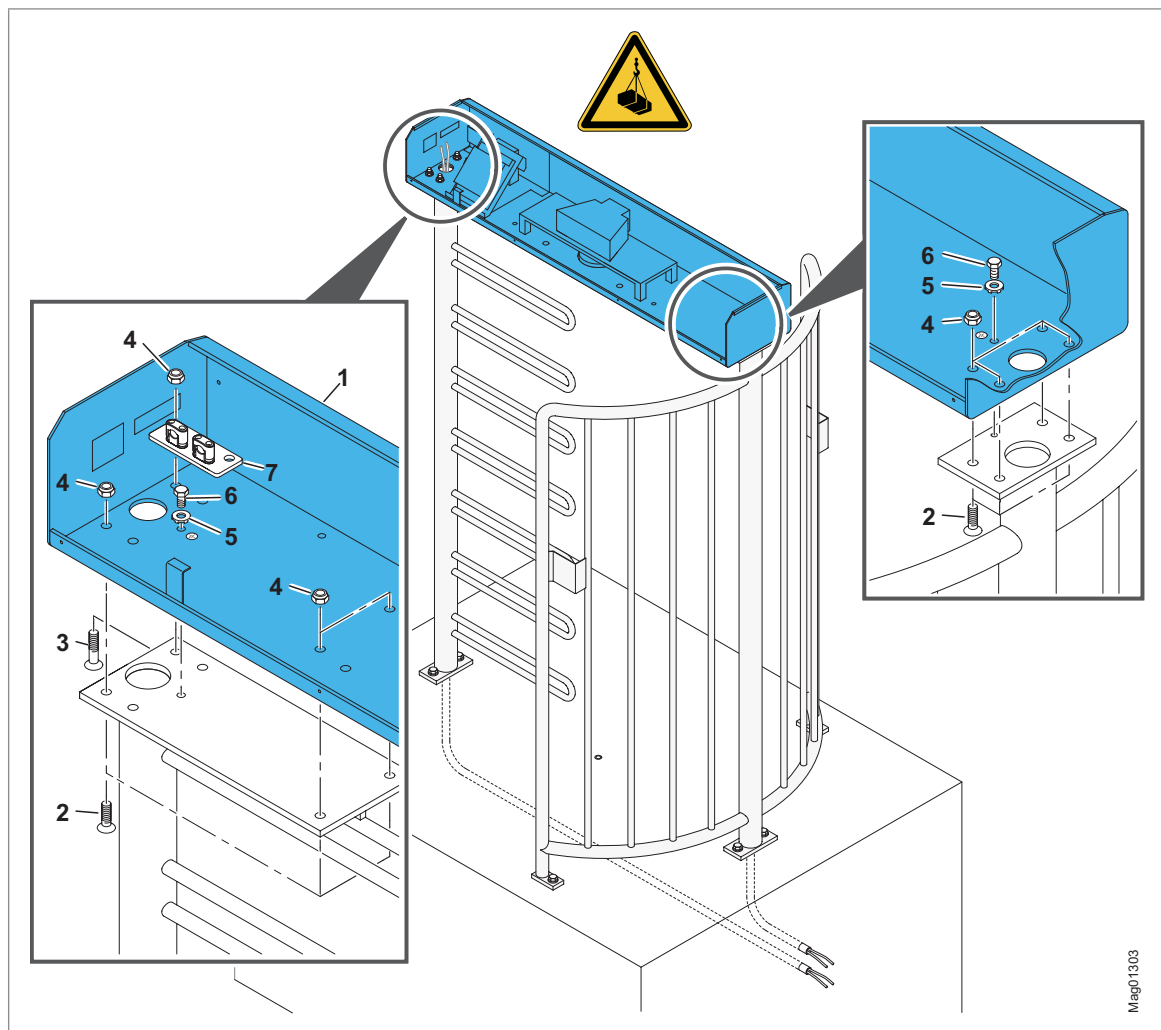

### 7.7.4 Mounting the floor bearing and centre pillar MPT-333 (3x120°)

#### Mounting the floor bearing

1. Mount the sleeve and washer with a hexagon head screw.
2. Slide the plastic bearing over the sleeve, washer, and hexagon head screw. The conical side of the plastic bearing must point downwards.

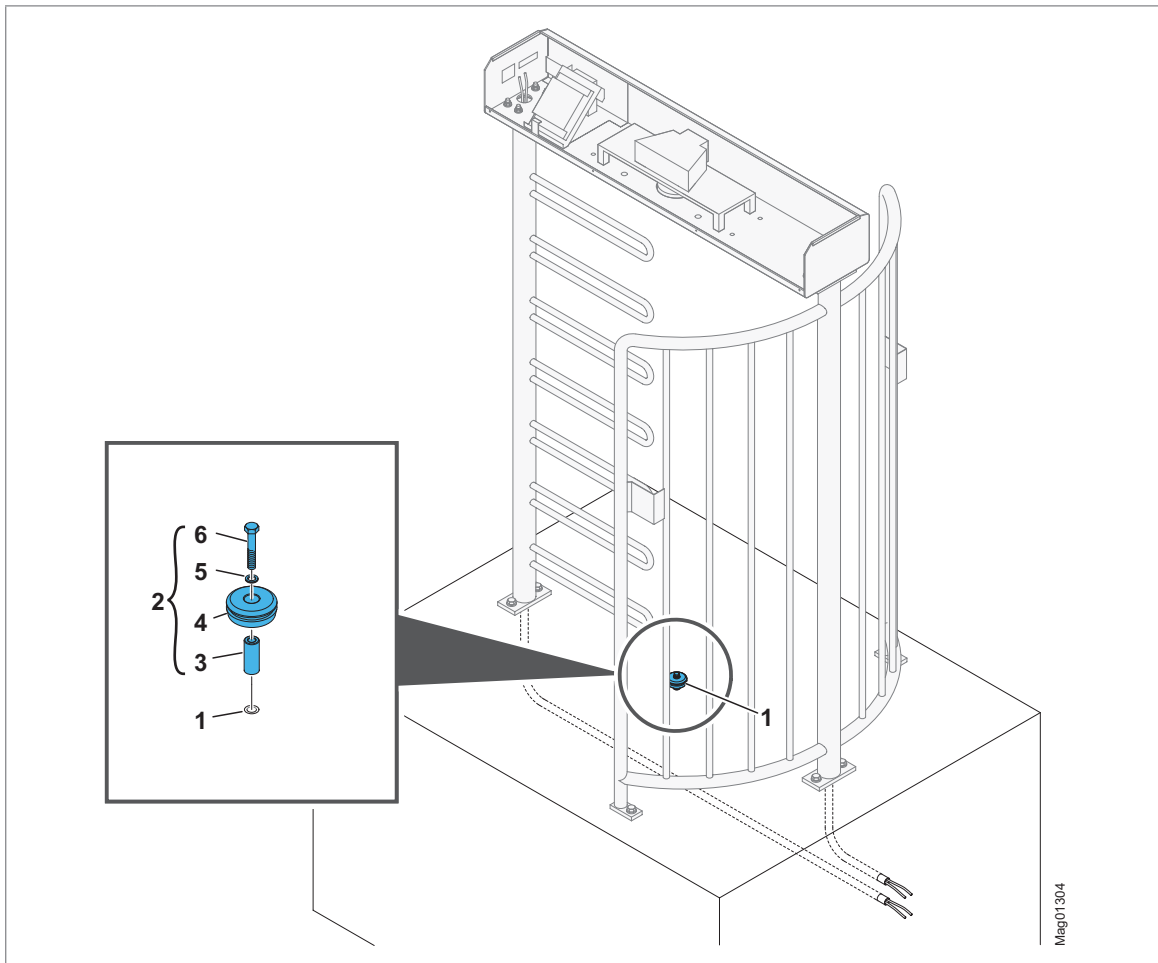

Fig. 31: Mounting the floor bearing – MPT-333 (3x120°)

- 1 Bore for sleeve with inner thread
- 2 Floor bearing
- 3 Sleeve
- 4 Plastic bearing
- 5 Washer
- 6 Hexagon head screw

### Mounting the centre pillar

1. Place the centre pillar on the floor bearing.

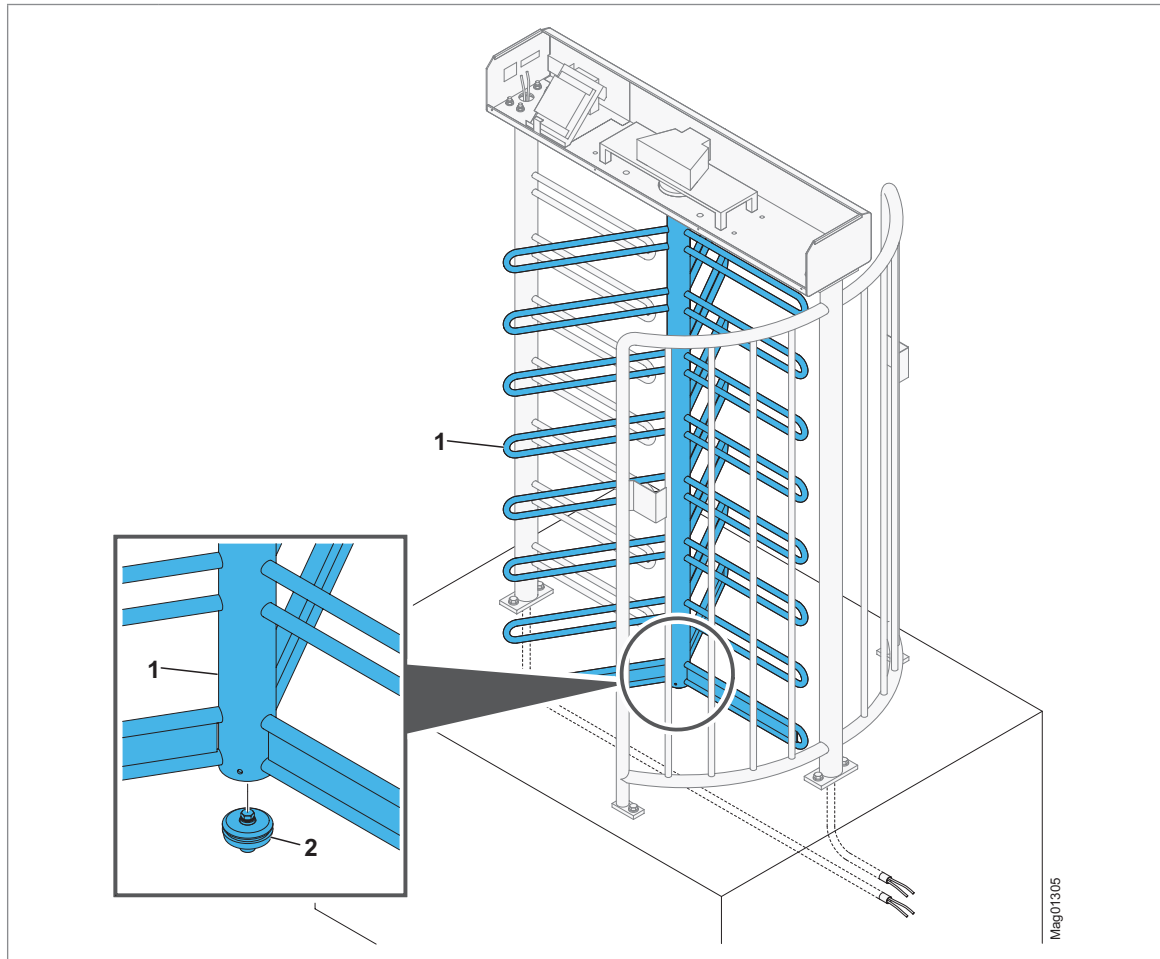

Fig. 32: Placing the centre pillar on floor bearing – MPT-333 (3x120°)

- 1 Centre pillar
- 2 Floor bearing

**IMPORTANT!**

The centre pillar is mounted on the flange of the locking via four screws. Before mounting the first screw, the locking must be in the home position and the bracket rows of the centre pillar must be in a certain position.

2. Make sure that the locking unit is in the home position.
  - › The countersink in the cam plate must point in the direction of the locking levers. The locking levers are open.

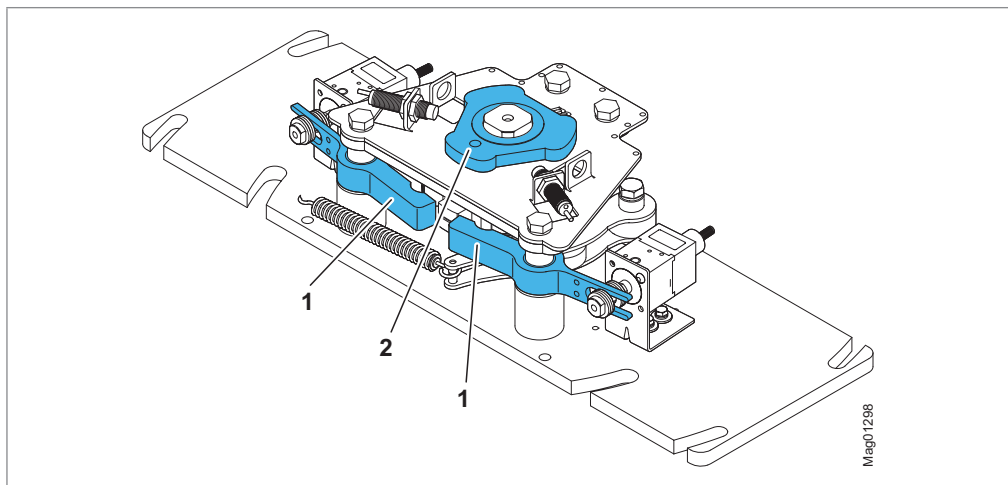

Fig. 33: Locking unit for centre pillar – MPT-3x3 (3x120°)

- 1 Locking lever, open
- 2 Countersink in the cam plate, points in the direction of the locking lever

3. Turn the centre pillar so that the countersink on the flange bottom of the centre pillar (pos. 2) points towards the locking comb (pos. 1). The centre pillar is in the locked position. The bracket row (pos. 3) opposite the countersink (pos. 2) is in the locked position.

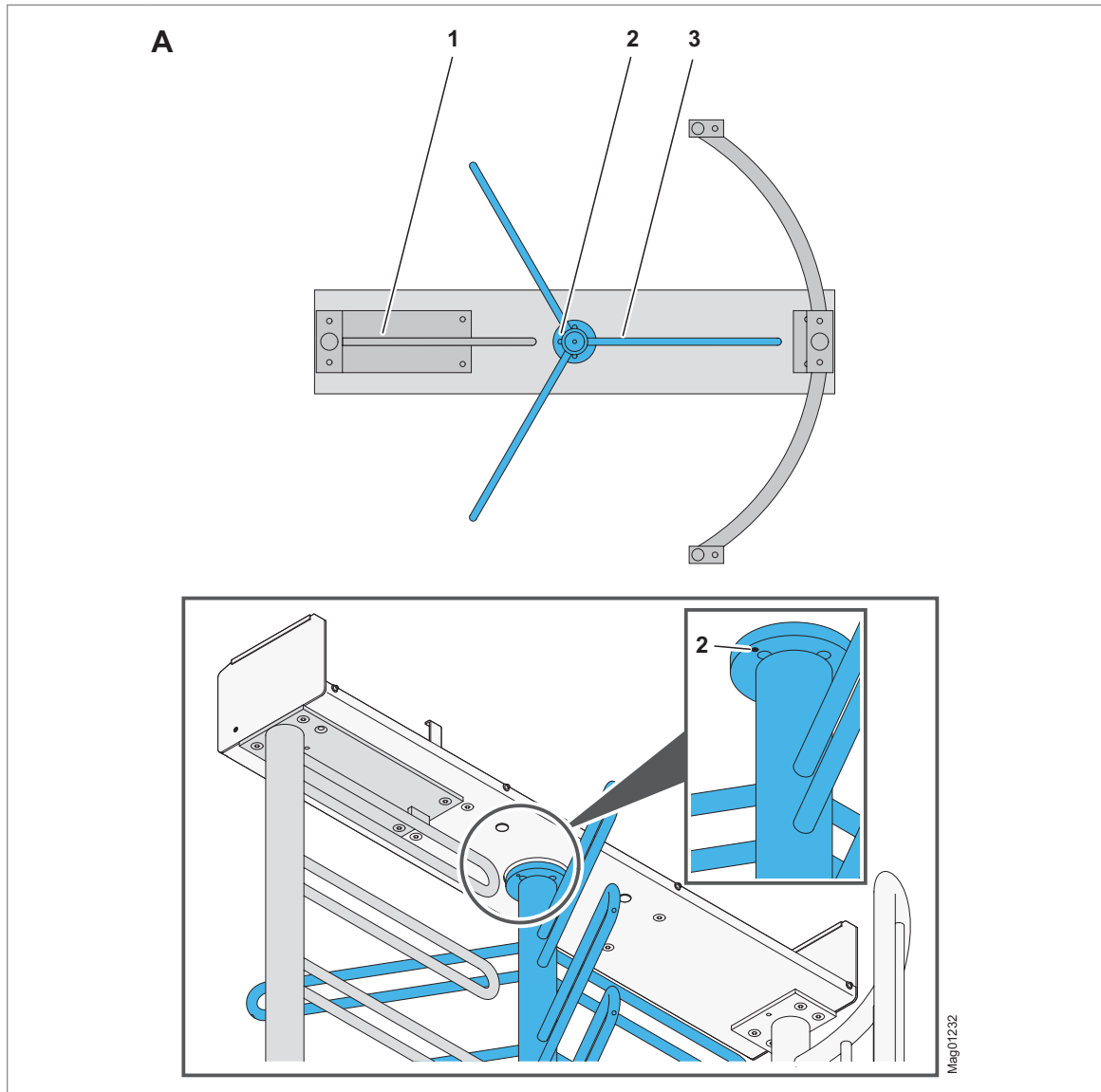

Fig. 34: Centre pillar alignment before mounting – MPT-333 (3x120°)

A Bottom view

1 Locking comb

2 Countersink on flange bottom of the centre pillar

3 Centre pillar bracket row is in locked position

4. Fix the centre pillar to the locking flange from above using the four screws supplied. Make sure that the centre pillar is correctly positioned in relation to the locking unit. ↗ Page 61, Fig. 34.
  - › Secure screws with threadlocker such as Loctite 241.
  - › Screw in two screws by hand, each with a wedge securing disc. Lift the centre pillar up to the locking flange.
  - › Turn the centre pillar so that the other two screws with the wedge securing discs can be screwed in.
  - › When all four screws are in place, tighten all screws firmly.

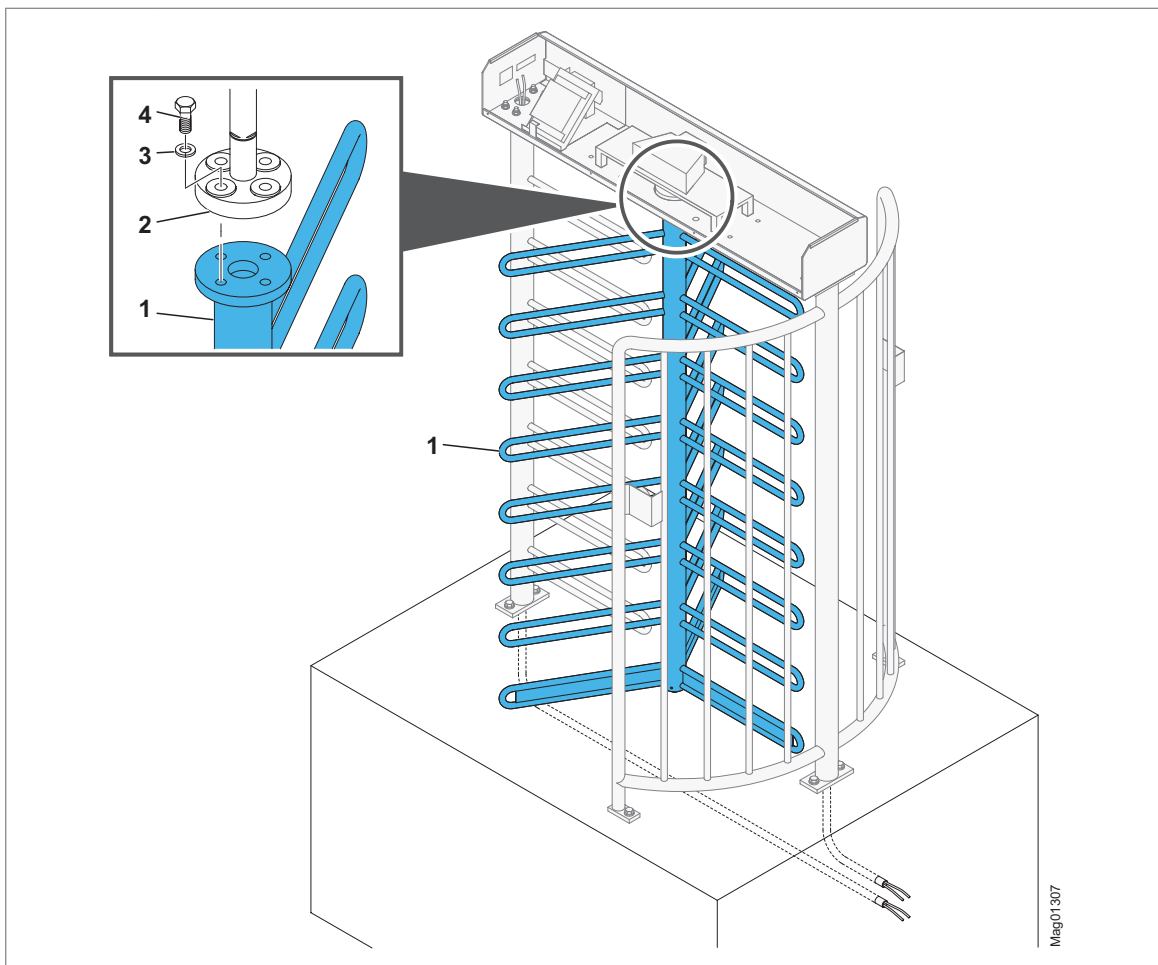

Fig. 35: Mounting the centre pillar on locking flange – MPT-333 (3x120°)

- 1 Centre pillar
- 2 Locking flange
- 3 Wedge securing discs
- 4 Securing screw with threadlocker such as Loctite 241

### Fixing the centre pillar to the floor bearing

1. Push the plastic bearing from below into the centre pillar until the plastic bearing is flush with the centre pillar.
2. Mount all 3 threaded pins as follows:
  - › Secure threaded pin with threadlocker such as Loctite 241.
  - › Screw in the threaded pin as far as it will go.
  - › Unscrew the threaded pin by half a turn.

The centre pillar must be easily rotatable in both rotating directions.

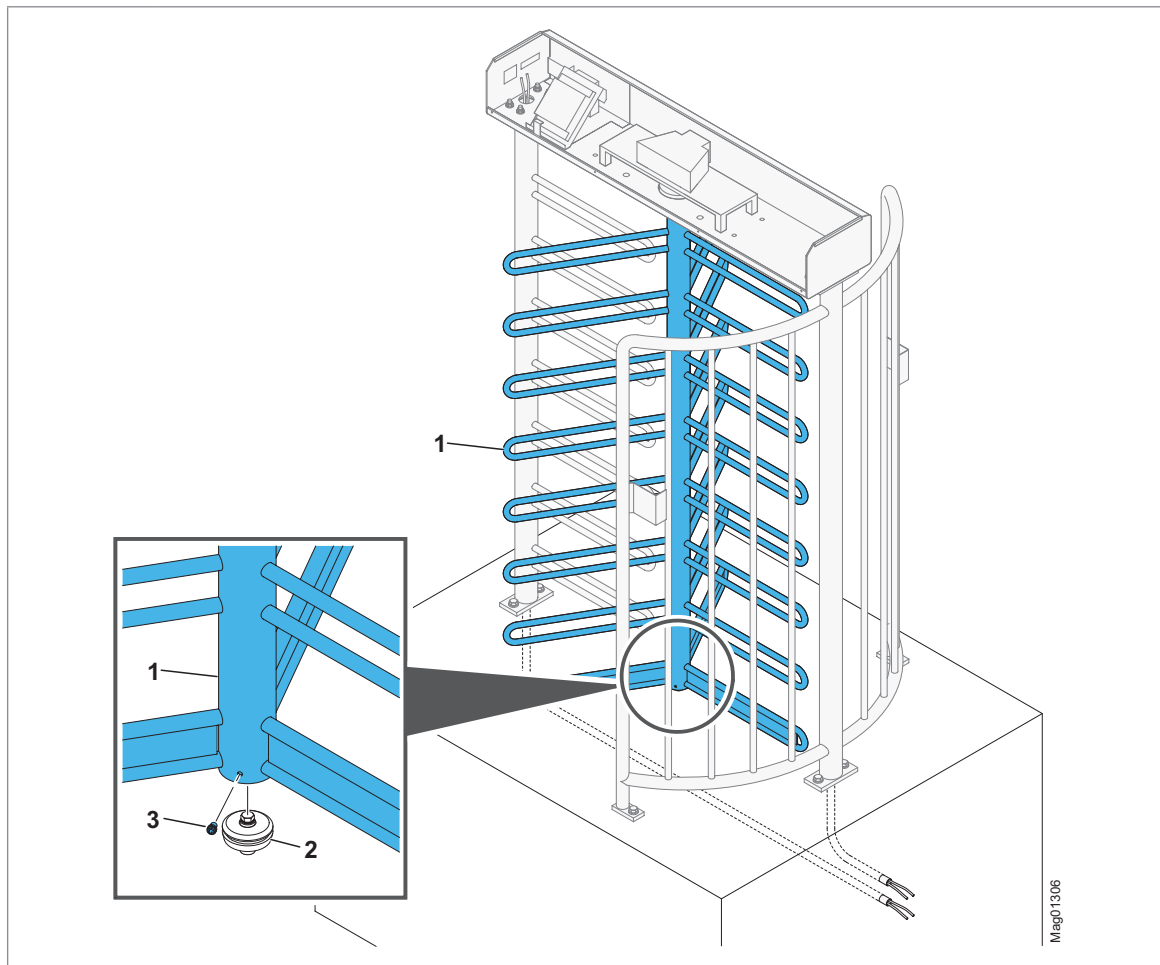

Fig. 36: Fixing the centre pillar to the floor bearing – MPT-333 (3x120°)

- 1 Centre pillar
- 2 Floor bearing
- 3 Threaded pin, secure with threadlocker such as Loctite 241 (3 pcs.)

### 7.7.5 Connecting two pedestrian gates MPT-333 (3x120°)

If the system consists of two pedestrian gates, we recommend mounting the VBSET connection set.

You must order the BSS101 connection set separately.

### 7.7.6 Closing the cover of the support beam MPT-333 (3x120°)



#### IMPORTANT!

For safe operation, the support beam, the cover, and the service door must be earthed. The service door and the cover are earthed via protective earth conductors, an earthing point on the cover and an earthing point on the support beam.

When the mounting work is completed or if the work is interrupted for a longer period of time, the support beam must be closed with the cover. We recommend checking that the protective earth conductors for the cover and the service door are correctly connected when closing the cover.

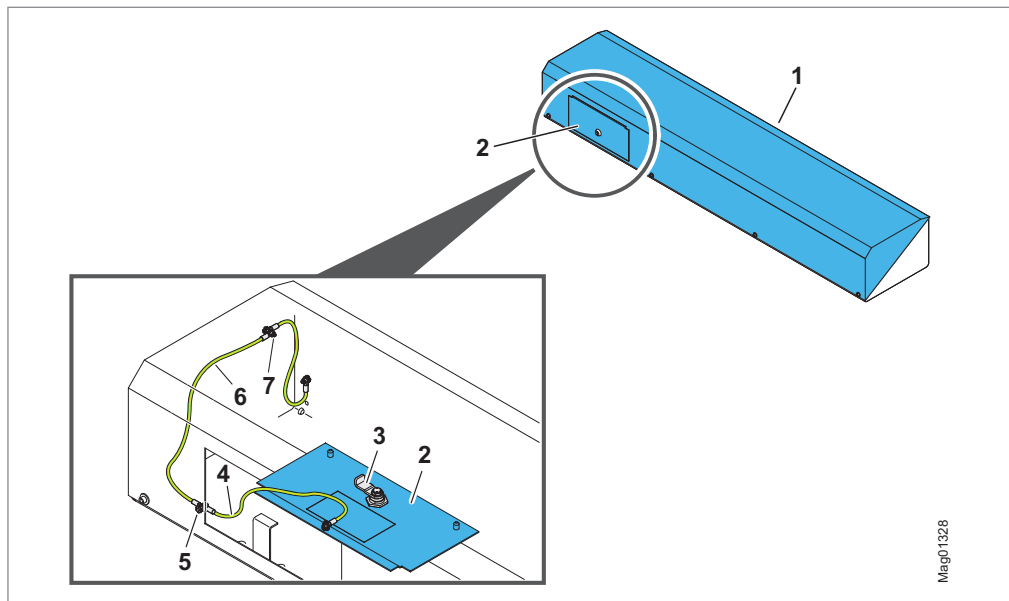

Fig. 37: Earthing of cover and service door (exemplary representation)

- 1 Cover
- 2 Service door
- 3 Lock (back)
- 4 Protective earth conductor for service door (protective earth conductor service door – cover)
- 5 Hood earthing point
- 6 Protective earth conductor for cover (protective earth conductor for cover – support beam)
- 7 Support beam earthing point



1. Put the cover onto the support beam from the front.
2. Secure the cover with the screws.

 DANGER

Danger to life if the protective earth conductor for the cover is not connected!

3. Connect the protective earth conductor for the cover to the earthing point for the cover.

 DANGER

Danger to life if the protective earth conductor for the service door is not connected!

4. Connect the protective earth conductor for the service door to the earthing point for the cover.
5. Close the service door.

## 7.8 Mounting the MPT-333 (4x90°)

The mounting of the pedestrian gate on a base frame and the mounting of the pedestrian gate directly on a foundation are identical in procedure. Only the attachment material is partly different. The following illustrations show the installation directly on a foundation.

### 7.8.1 Mounting the locking comb and cage half MPT-333 (4x90°)

1. Pull the mains cable and control lines through the support of the locking comb. Alternatively, you can also pull the cables through the support of the cage half.
2. Mount the locking comb.

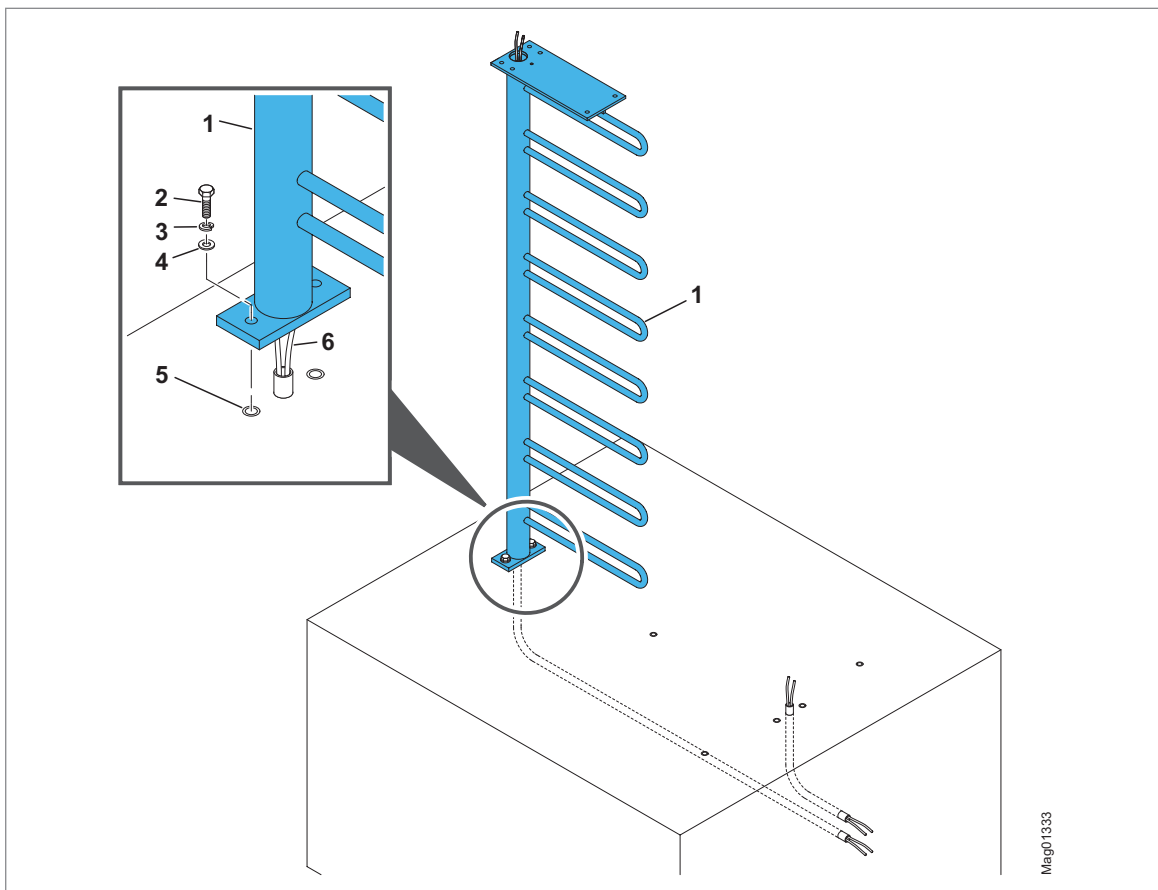

Fig. 38: Mounting the locking comb – MPT-333 (4x90°)

- 1 Locking comb
- 2 Hexagon head screw M10 x 35
- 3 Spring washer
- 4 Washer D10.5
- 5 Bore with sleeve with inner thread
- 6 Mains cable and control lines (example)

3. Mount the cage half. If necessary, pull lines through the support.

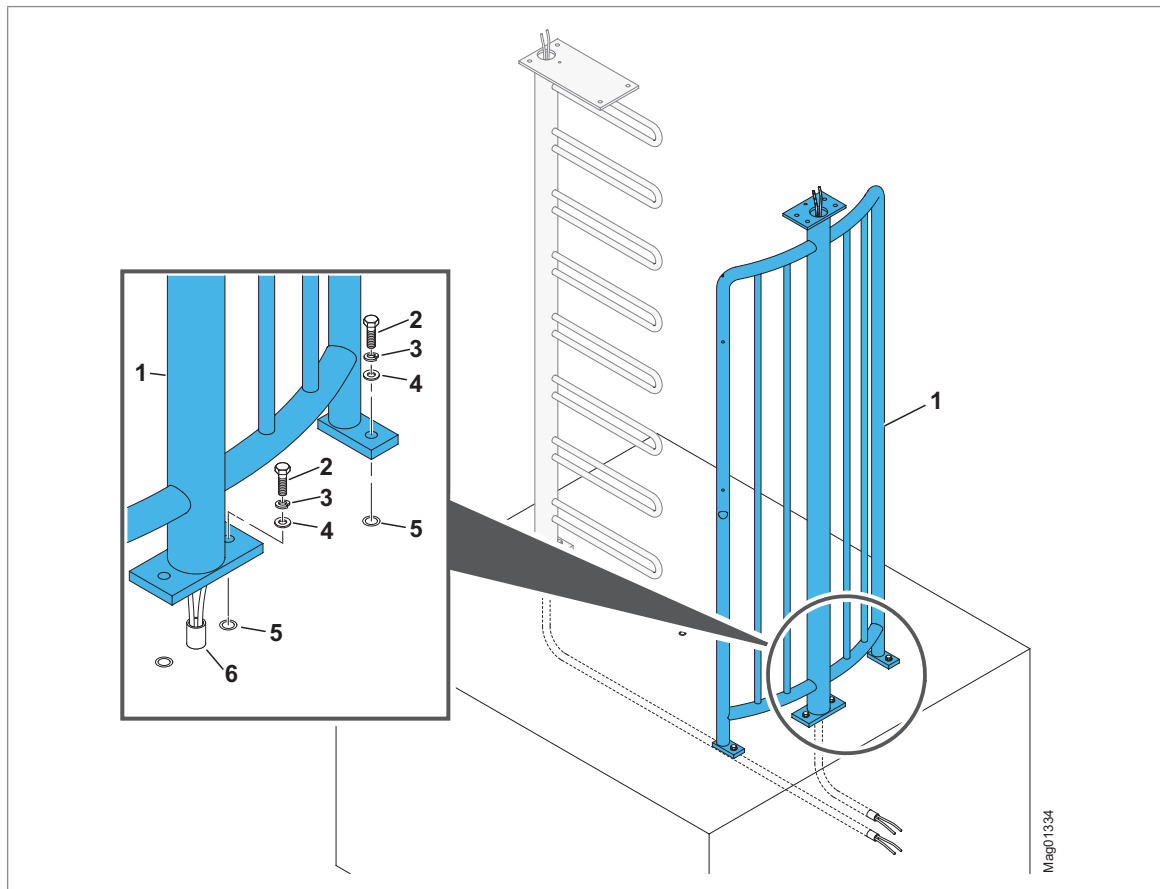

Fig. 39: Mounting the cage half – MPT-333 (4x90°)

- 1 Cage half (standard)
- 2 Hexagon head screw M10 x 35
- 3 Spring washer
- 4 Washer D10.5
- 5 Bore with sleeve with inner thread
- 6 Mains cable and control lines (alternative)

### 7.8.2 Mounting the support beam MPT-333 (4x90°)

The support beam is delivered with the cover closed. The service door and the cover must be removed and the protective earth conductors for the service door and for the cover must be disconnected for mounting.

1. Open the service door with the supplied key.
2. Disconnect the protective earth conductor for the service door at the earthing point for the cover.
3. Put the service door aside.
4. Disconnect the protective earth conductor for the cover at the earthing point for the cover.

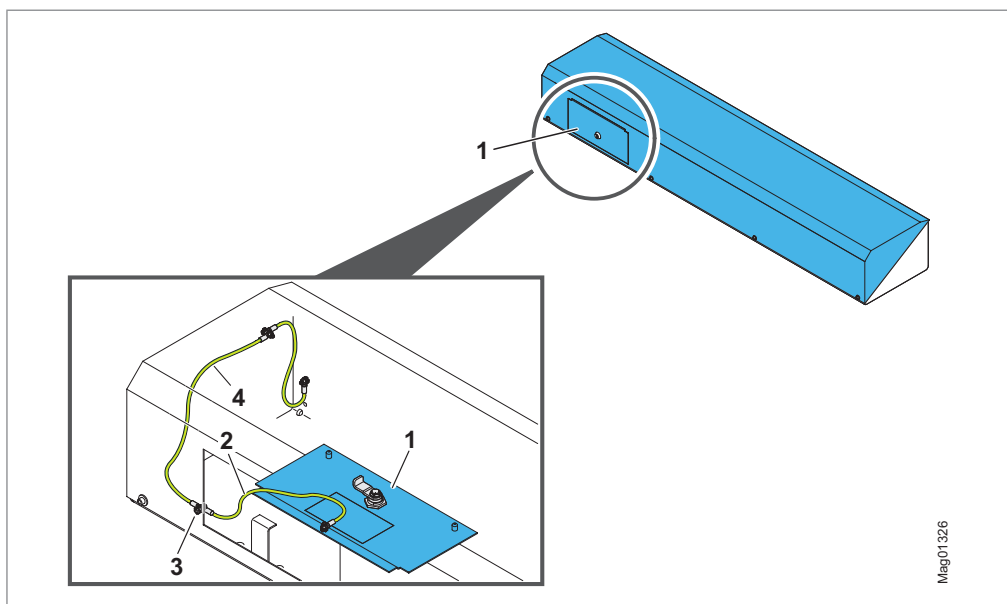

Fig. 40: Disconnect the protective earth conductor from the service door and cover

- 1 Service door
- 2 Protective earth conductor for service door
- 3 Hood earthing point
- 4 Protective earth conductor for cover

5. Loosen the screw of the cover.
6. Pull the cover to the front and remove it.

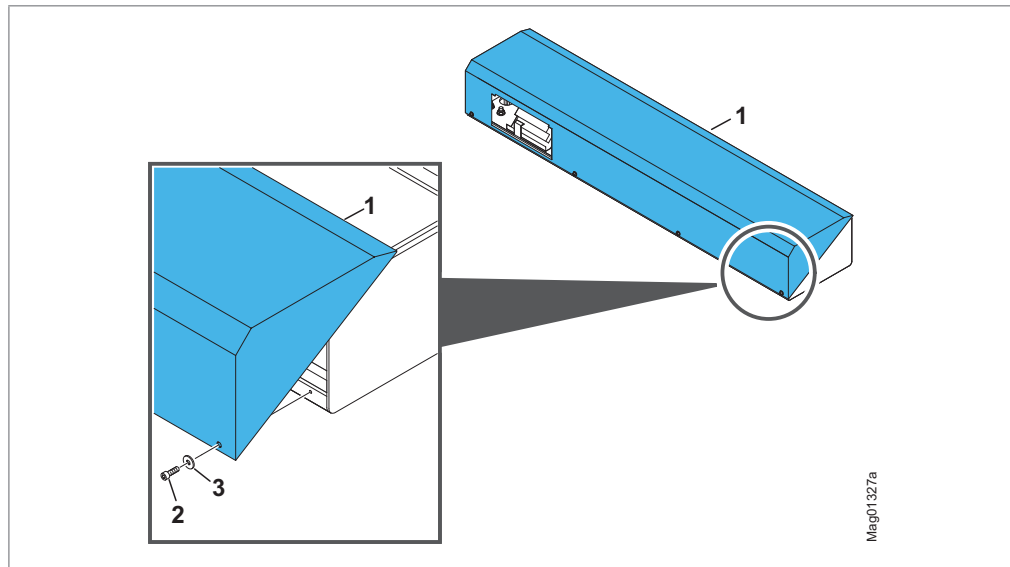

Fig. 41: Opening the cover

- 1 Cover
- 2 Screw
- 3 Washer

7. Prepare the support beams for assembly. For example, place support beams on the forks of a forklift truck. Secure the support beams against slipping, e.g., with screw clamps on the forks.

**⚠ WARNING**

Risk of injury from a falling support beam!

8. Place the support beam on the cage half and on the locking comb. At the same time, pull the lines through the bores in the bottom of the support beam.
9. Immediately secure the support beam using the countersunk screws supplied. Tighten the countersunk screws.
10. Ground the support beam on both sides using the contact disc and the hexagon head screws supplied.
11. Mount the tension relief on the support beam.

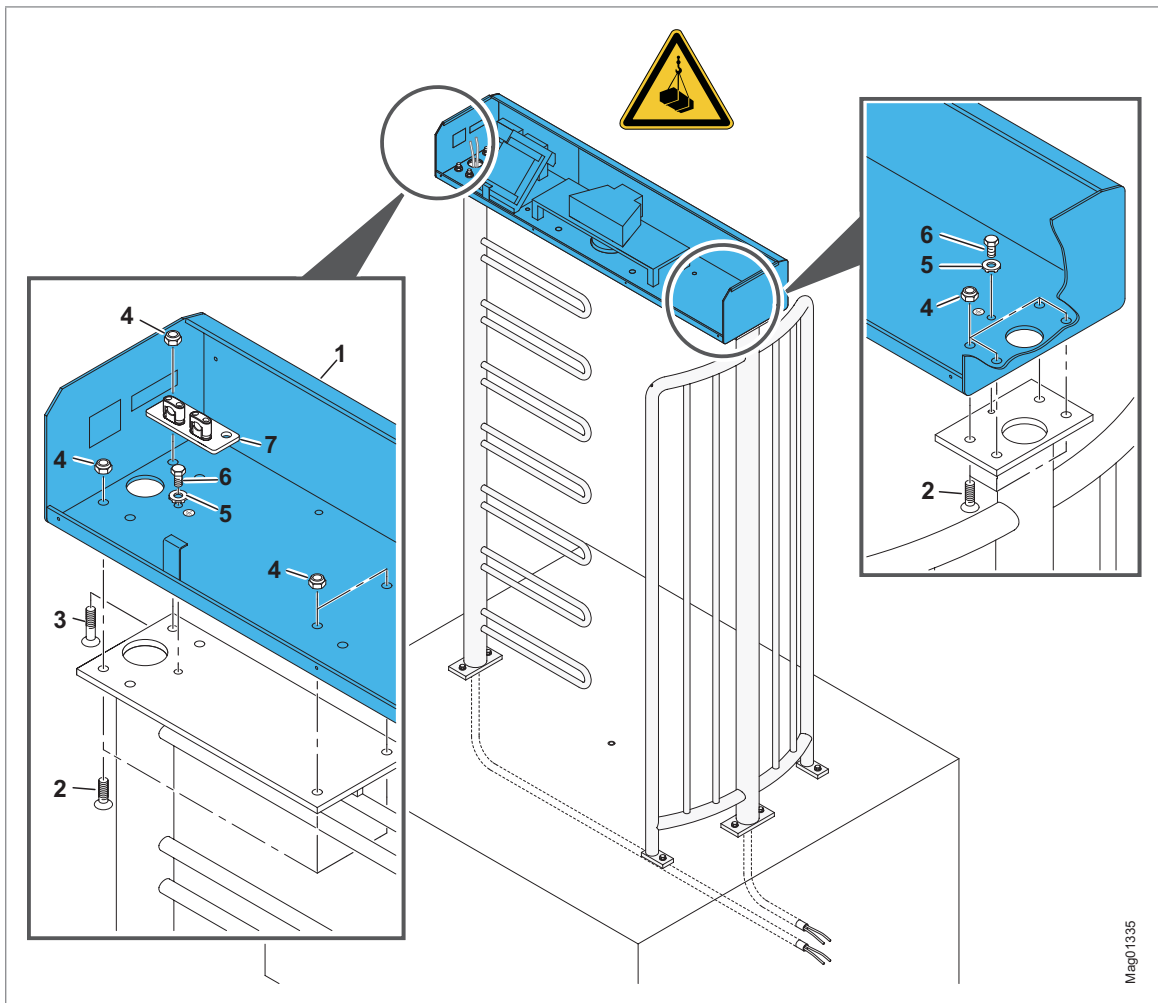

Fig. 42: Placing, earthing, and mounting the support beams – MPT-333 (4x90°)

- 1 Support beam
- 2 Countersunk screw
- 3 Countersunk screw
- 4 Nut M12
- 5 Contact disc M10
- 6 Hexagon head screw M10 x 20 for grounding the support beam
- 7 Tension relief for mains cable and control lines

### 7.8.3 Mounting the floor bearing and centre pillar MPT-333 (4x90°)

#### Mounting the floor bearing

1. Mount the sleeve and washer with a hexagon head screw.
2. Slide the plastic bearing over the sleeve, washer, and hexagon head screw. The conical side of the plastic bearing must point downwards.

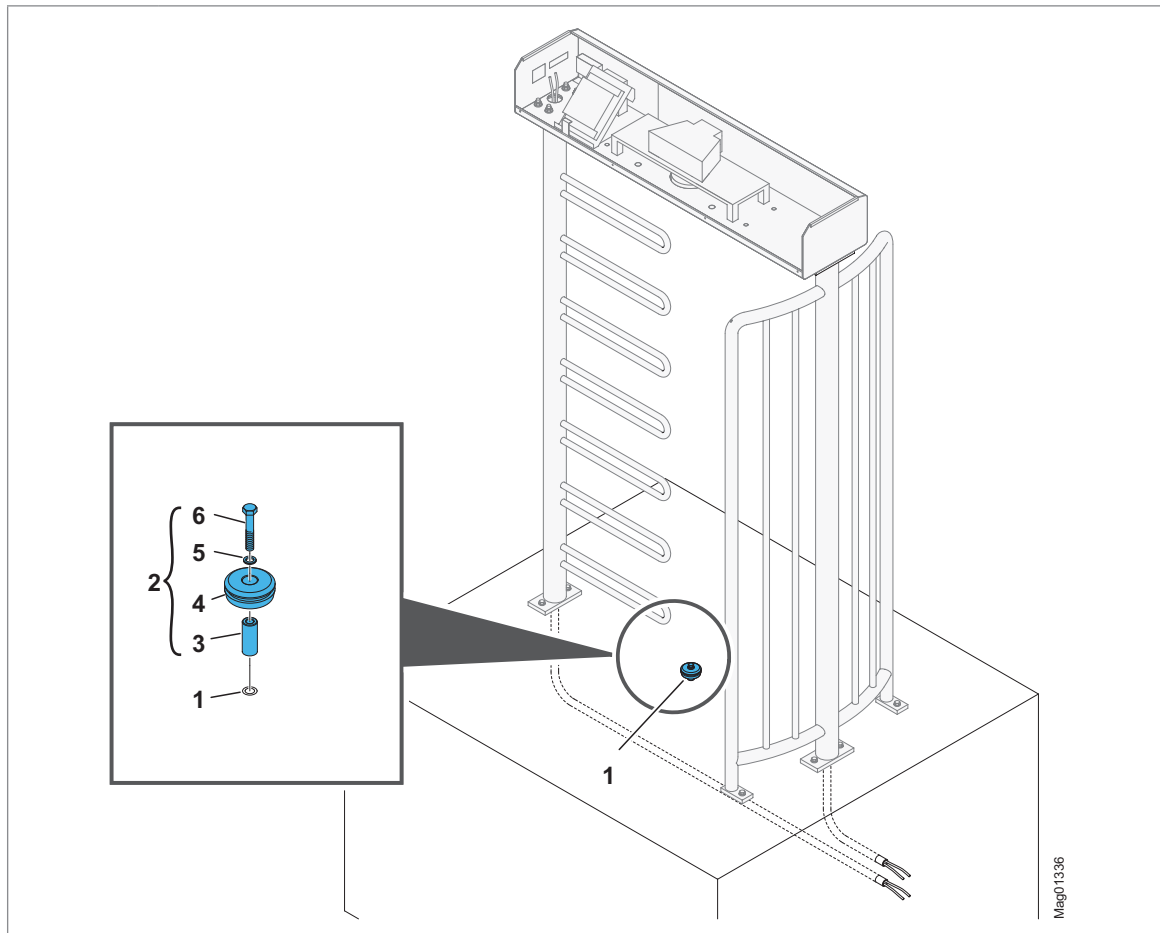

Fig. 43: Mounting the floor bearing – MPT-333 (4x90°)

- 1 Bore for sleeve with inner thread
- 2 Floor bearing
- 3 Sleeve
- 4 Plastic bearing
- 5 Washer
- 6 Hexagon head screw

**Mounting the centre pillar**

- 1. Place the centre pillar on the floor bearing.

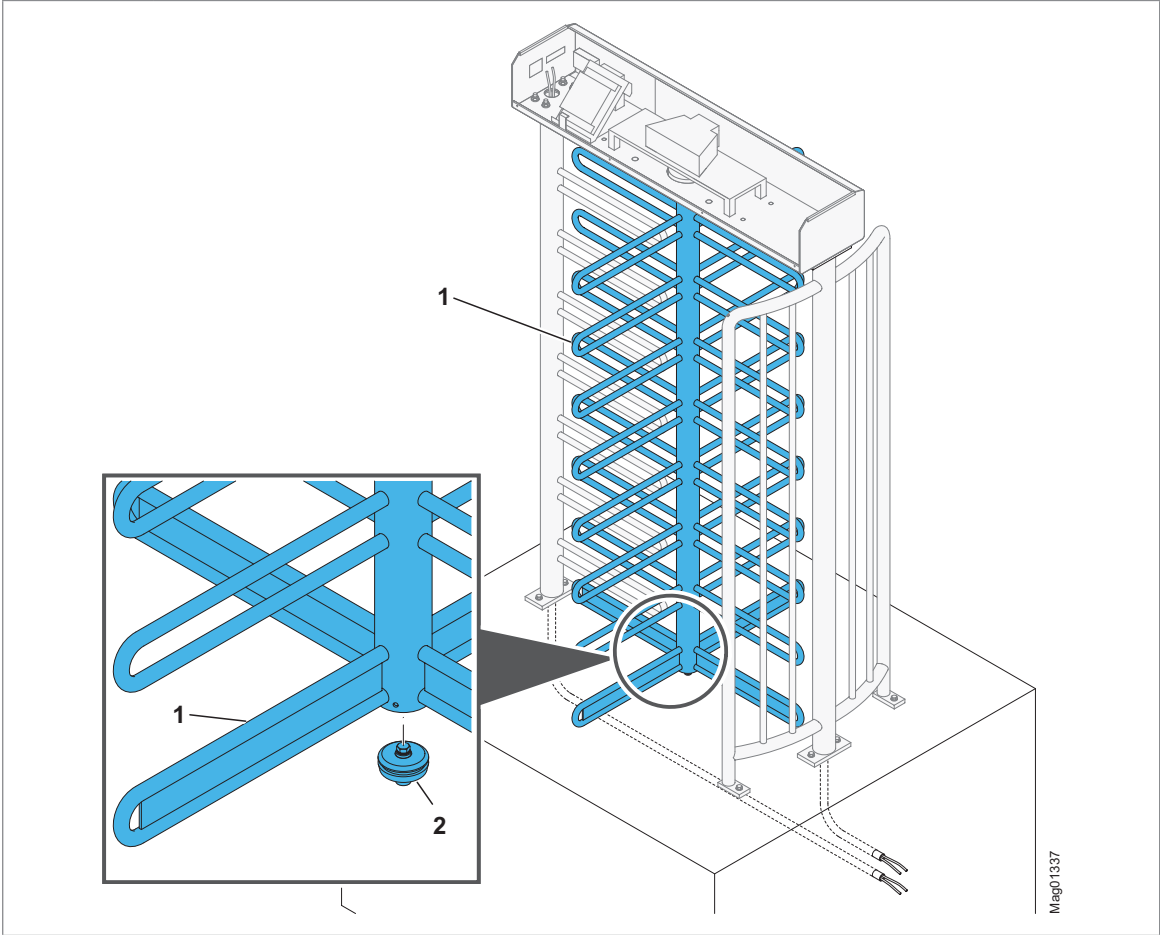

Fig. 44: Placing the centre pillar on floor bearing – MPT-333 (4x90°)  
1 Centre pillar  
2 Floor bearing





**IMPORTANT!**

The centre pillar is mounted on the flange of the locking via four screws. Before mounting the first screw, the locking must be in the home position and the bracket rows of the centre pillar must be in a certain position.

2. Make sure that the locking unit is in the home position.
  - › The cam plate should be aligned as follows. The locking levers are open.

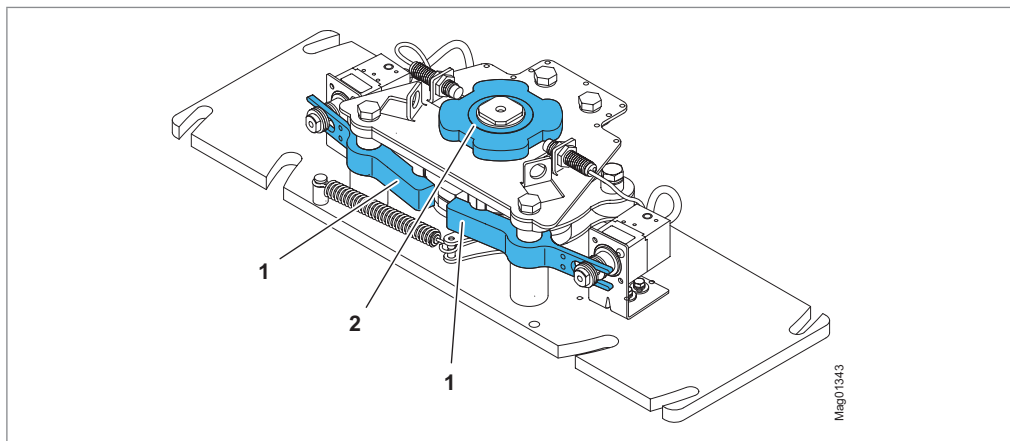

Fig. 45: Locking unit for centre pillar – MPT-3x3 (4x90°)

- 1 Locking lever, open
- 2 Alignment of the cam plate

3. Turn the centre pillar (pos. 2) so that one bracket row (pos. 2) is in the locked position.

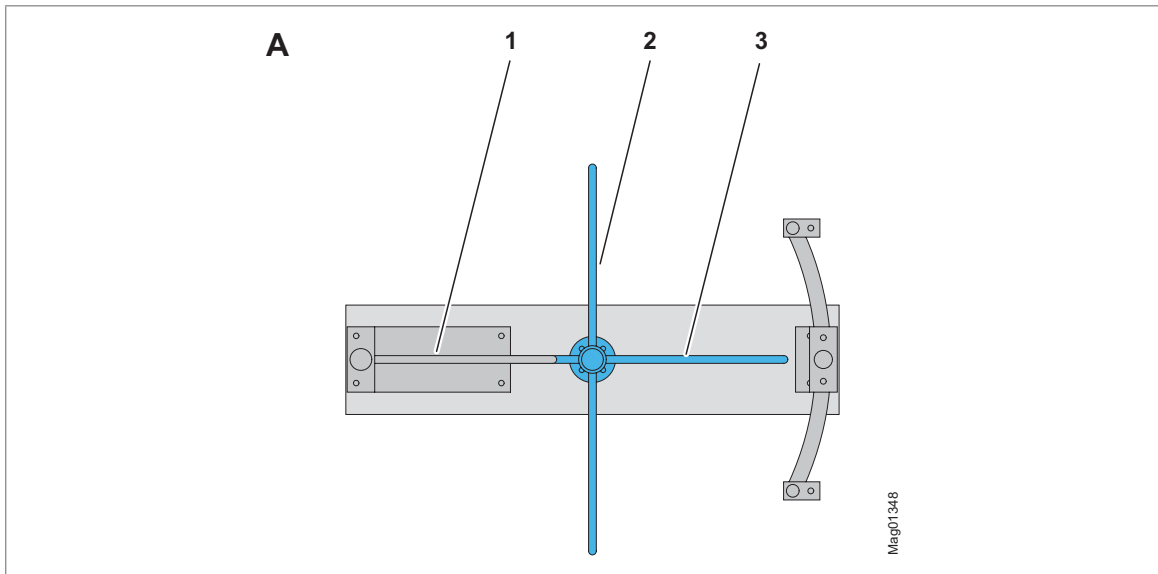

Fig. 46: Centre pillar alignment before mounting – MPT-333 (4x90°)

- A Bottom view
- 1 Locking comb
- 2 Centre pillar
- 3 Centre pillar bracket row is in locked position

4. Fix the centre pillar to the locking flange from above using the four screws supplied. Make sure that the centre pillar is correctly positioned in relation to the locking unit. ↗ Page 74, Fig. 46.
  - › Secure screws with threadlocker such as Loctite 241.
  - › Screw in two screws by hand, each with a wedge securing disc. Lift the centre pillar up to the locking flange.
  - › Turn the centre pillar so that the other two screws with the wedge securing disc can be screwed in.
  - › When all four screws are in place, tighten all screws firmly.

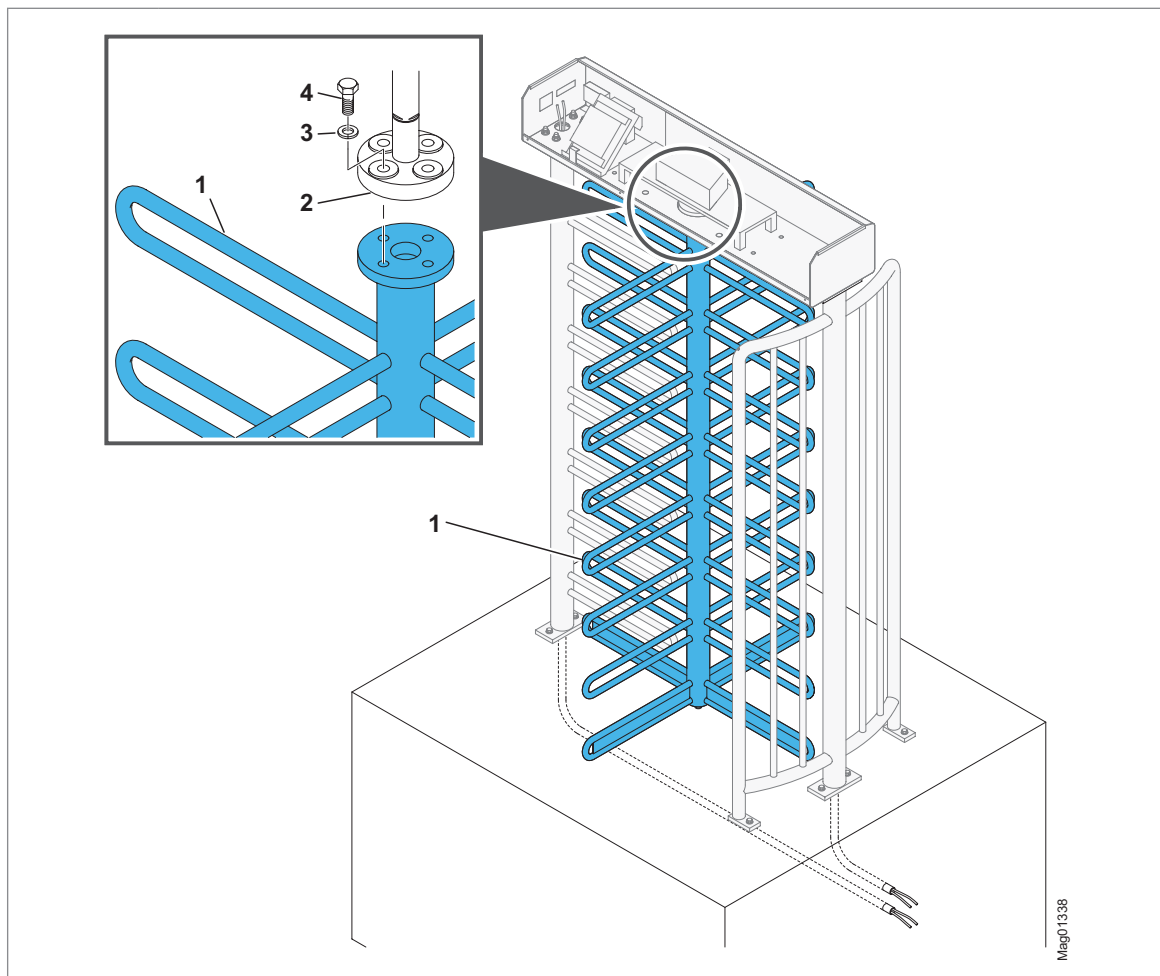

Fig. 47: Mounting the centre pillar on locking flange – MPT-333 (4x90°)

- 1 Centre pillar
- 2 Locking flange
- 3 Wedge securing discs
- 4 Securing screw with threadlocker such as Loctite 241

**Fixing the centre pillar to the floor bearing**

1. Push the plastic bearing from below into the centre pillar until the plastic bearing is flush with the centre pillar.
2. Mount all 4 threaded pins as follows:
  - › Secure threaded pin with threadlocker such as Loctite 241.
  - › Screw in the threaded pin as far as it will go.
  - › Unscrew the threaded pin by half a turn.

The centre pillar must be easily rotatable in both rotating directions.

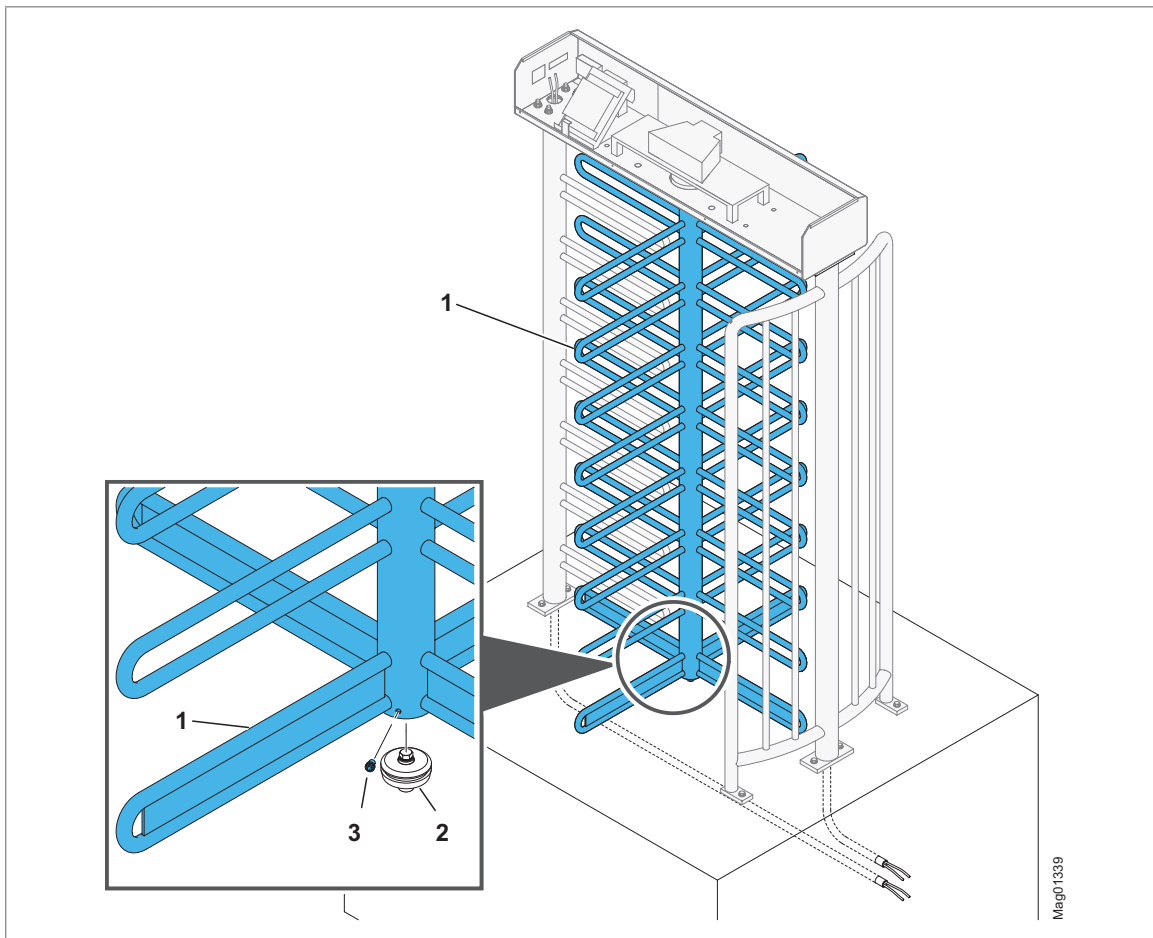

Fig. 48: Fixing the centre pillar to the floor bearing – MPT-333 (4x90°)

- 1 Centre pillar
- 2 Floor bearing
- 3 Threaded pin, secure with threadlocker such as Loctite 241 (4 pcs.)

#### 7.8.4 Connecting two pedestrian gates MPT-333 (4x90°)

If the system consists of two pedestrian gates, we recommend mounting the VBSET connection set.

You must order the BSS101 connection set separately.

#### 7.8.5 Closing the cover of the support beam MPT-333 (4x90°)



##### IMPORTANT!

For safe operation, the support beam, the cover, and the service door must be earthed. The service door and the cover are earthed via protective earth conductors, an earthing point on the cover and an earthing point on the support beam.

When the mounting work is completed or if the work is interrupted for a longer period of time, the support beam must be closed with the cover. We recommend checking that the protective earth conductors for the cover and the service door are correctly connected when closing the cover.

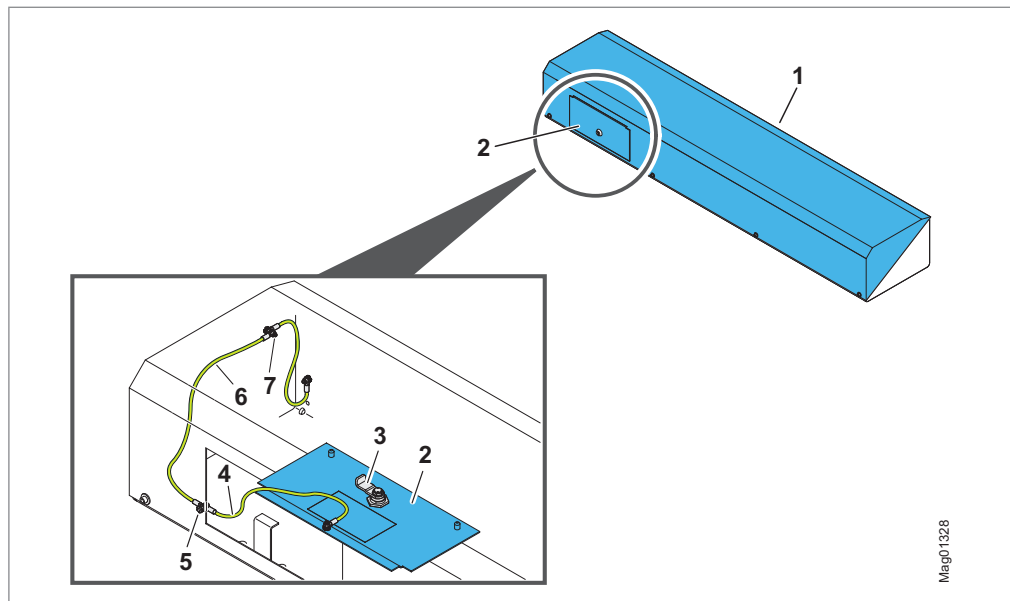

Fig. 49: Earthing of cover and service door (exemplary representation)

- 1 Cover
- 2 Service door
- 3 Lock (back)
- 4 Protective earth conductor for service door (protective earth conductor service door – cover)
- 5 Hood earthing point
- 6 Protective earth conductor for hood (protective earth conductor service door – cover)
- 7 Support beam earthing point

1. Put the cover onto the support beam from the front.
2. Secure the cover with the screws.

**⚠ DANGER**

Danger to life if the protective earth conductor for the cover is not connected!

3. Connect the protective earth conductor for the cover to the earthing point for the cover.

**⚠ DANGER**

Danger to life if the protective earth conductor for the service door is not connected!

4. Connect the protective earth conductor for the service door to the earthing point for the cover.
5. Close the service door.

## **7.9 Checking the mounting**

Check the following points after mounting:

- › Are all foundation anchors tightened?
- › Are all attachment screws firmly tightened?
- › Is the support beam earthed?
- › Is the support beam closed with the cover?
- › Is the protective earth conductor for the cover connected?
- › Is the protective earth conductor for the service door connected?
- › Is the cover mounted correctly?
- › Is the service door in the cover locked?

## 8 Mounting the optional mounting pillar for access-control devices



### IMPORTANT!

Magnetic offers the mounting pillar ASMP as attachment for the installation of access-control devices.

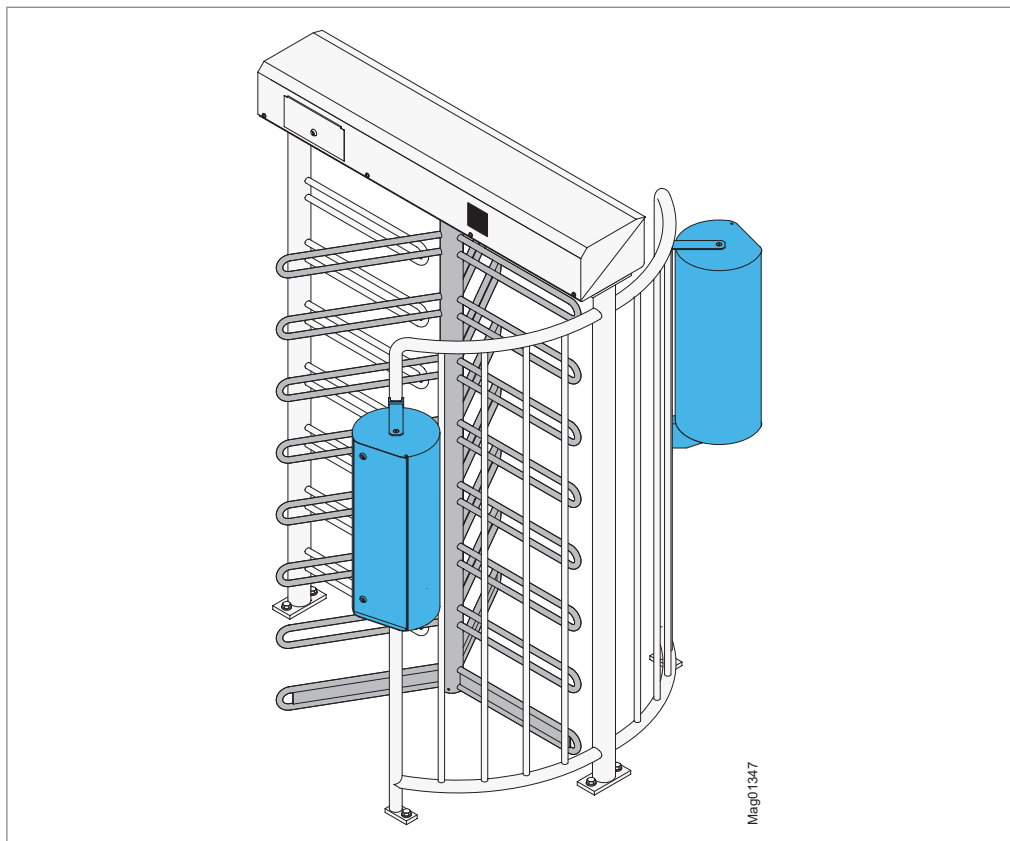

Fig. 50: Optional mounting pillars – example MPT-333 (3x120°)

If the mounting pillars were ordered at the same time as the pedestrian gate, pull wires for the lines of the mounting pillars are pulled in at the factory.

## Mounting the optional mounting pillar for access-control devices

### Additional steps for the subsequent ordering of the mounting pillar

If the mounting pillars are ordered subsequently, you must carry out the following steps before mounting the mounting pillars:

1. Drill two holes for either M8 threads or M8 blind rivet nuts for the mounting pillars in the cage half.
2. Either place a M8 blind rivet nut or cut a M8 thread in the holes.
3. Drill a hole with a diameter of 30 mm for the pull wires and lines.

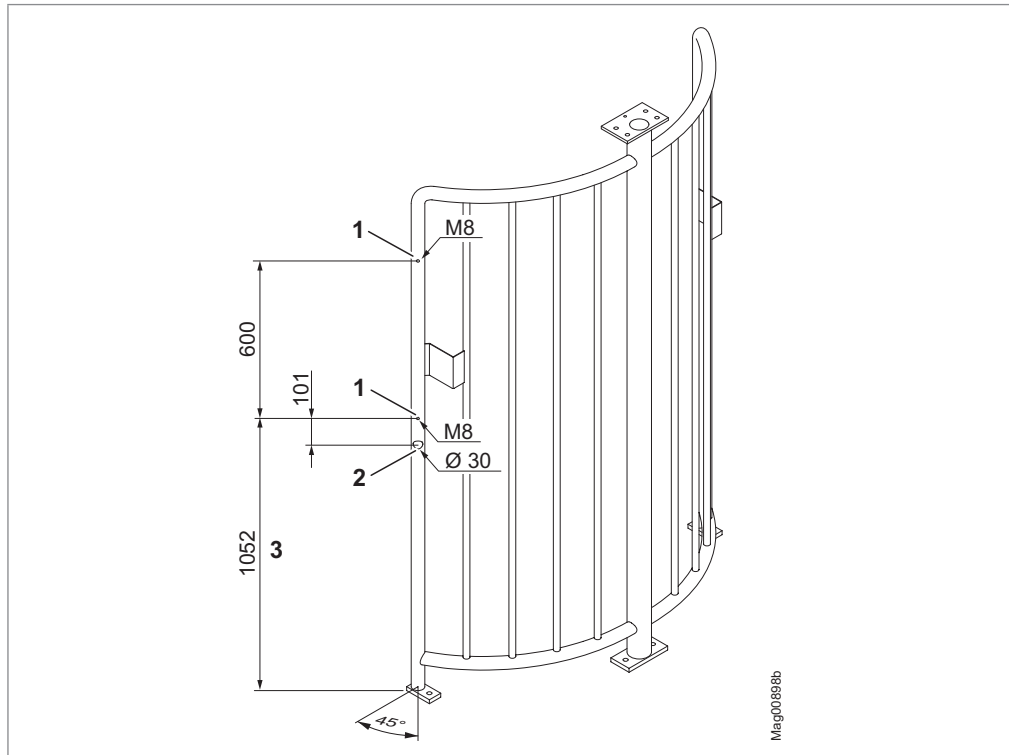

Fig. 51: Required holes for mounting pillar (all size in mm)

- 1 Borehole either for M8 blind rivet nut or M8 thread for fastening the U-profile (2x)
- 2 Borehole diameter 30 mm for pull wires and lines (1x)
- 3 Standard height for implementation by Magnetic
4. Pull the pull wires or lines for the mounting pillar through the outer supports of the cage half.



Mounting the mounting pillar

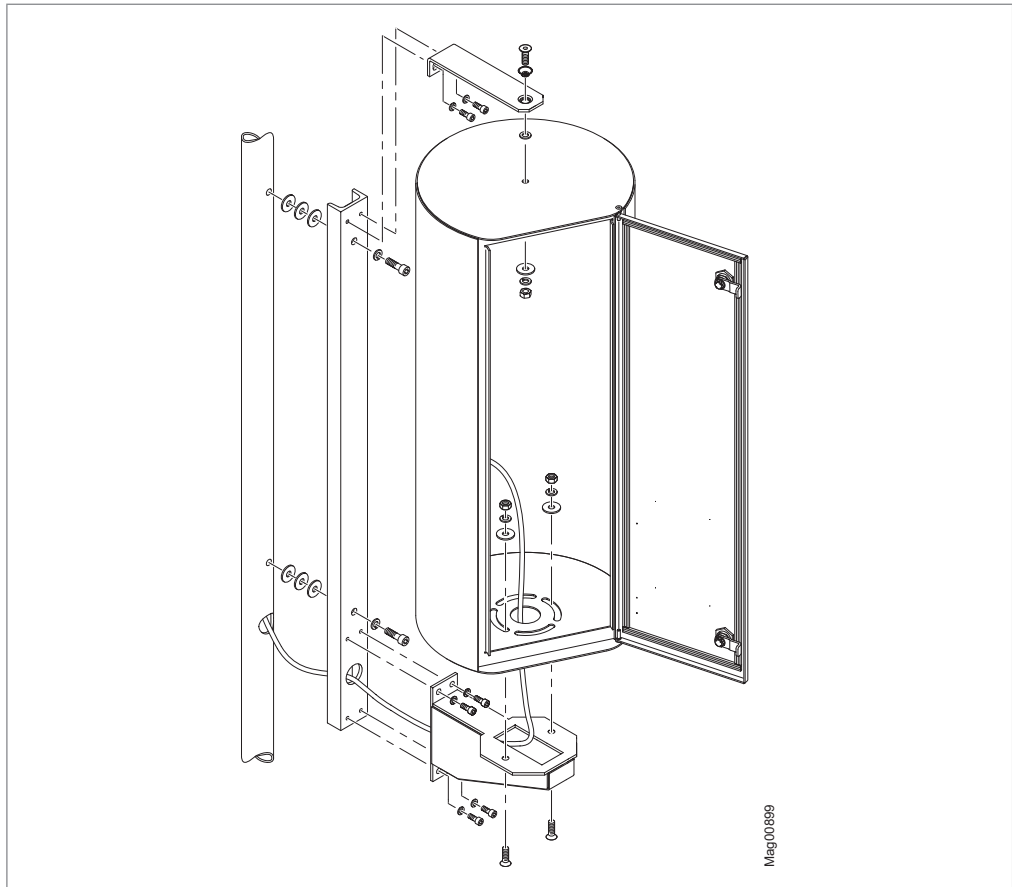

Fig. 52: Mounting pillar and attachment material

## Mounting the optional mounting pillar for access-control devices

---

1. Mount the U-profile to the outer support of the cage half.

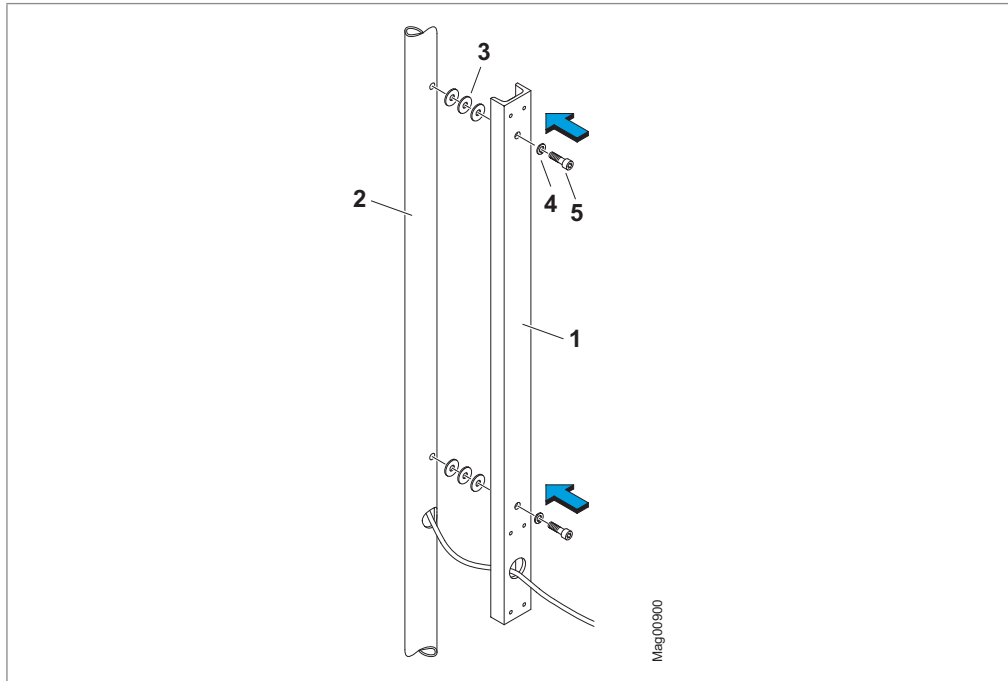

Fig. 53: Mounting the U-profile

- 1 U-profile
- 2 Outer support cage half
- 3 Washer D8.4
- 4 Spring washer A8
- 5 Hexagon socket screw M8 x 30

**Mounting the optional mounting pillar for access-control devices**

2. Mount the lower holder.

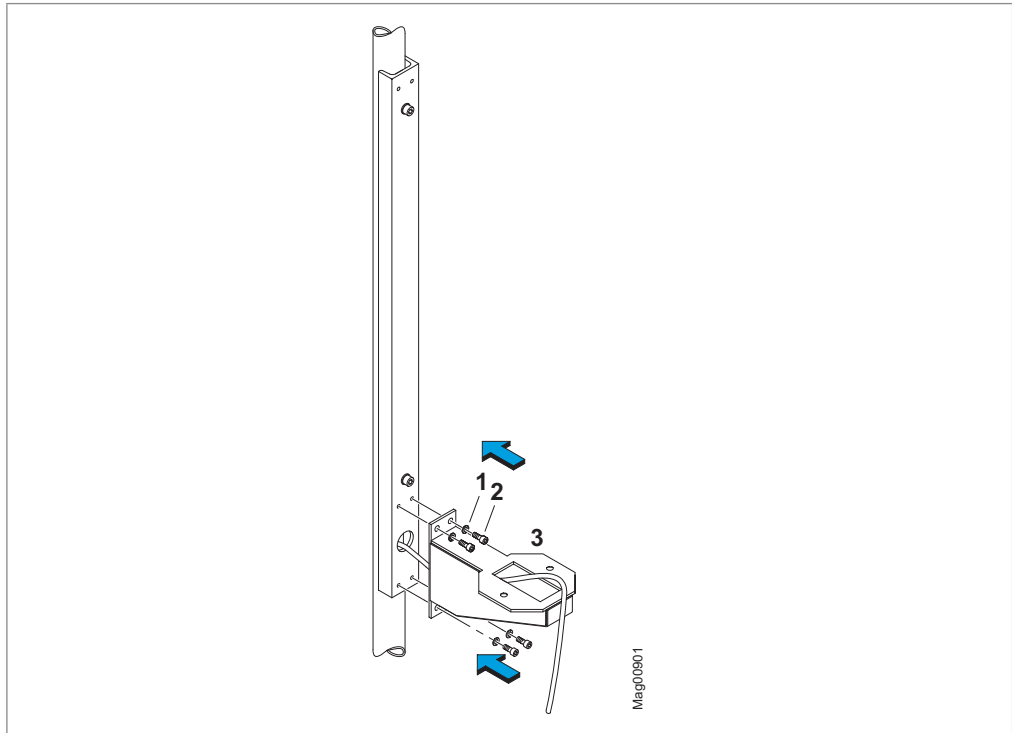

Fig. 54: Mounting the lower holder

- 1 Spring washer A6
- 2 Screw M6 x 16
- 3 Holder

## Mounting the optional mounting pillar for access-control devices

3. Mount the attachment angle to the mounting pillar. Tighten nut by hand.

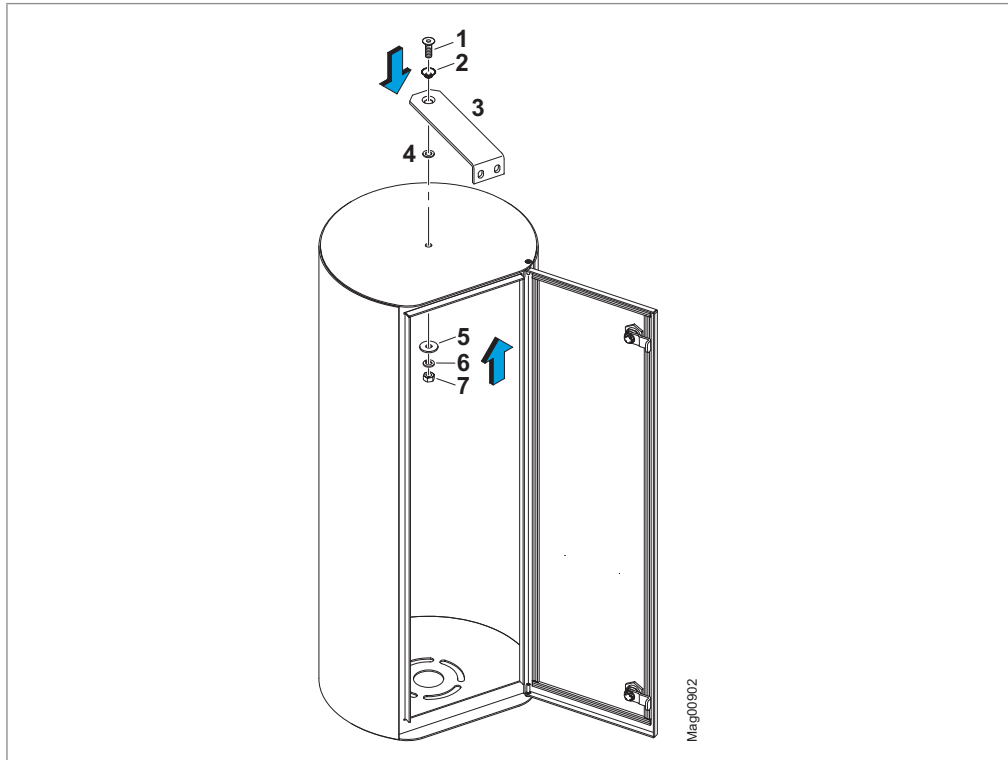

Fig. 55: Mounting the attachment angle

- 1 Screw DIN 7991 M8 x 25
- 2 Sleeve
- 3 Attachment angles
- 4 Washer PE D8.4
- 5 Washer D8.4
- 6 Spring washer A8
- 7 Nut M8

**Mounting the optional mounting pillar for access-control devices**

4. Mount the attachment angle with mounting pillar to the U-profile.

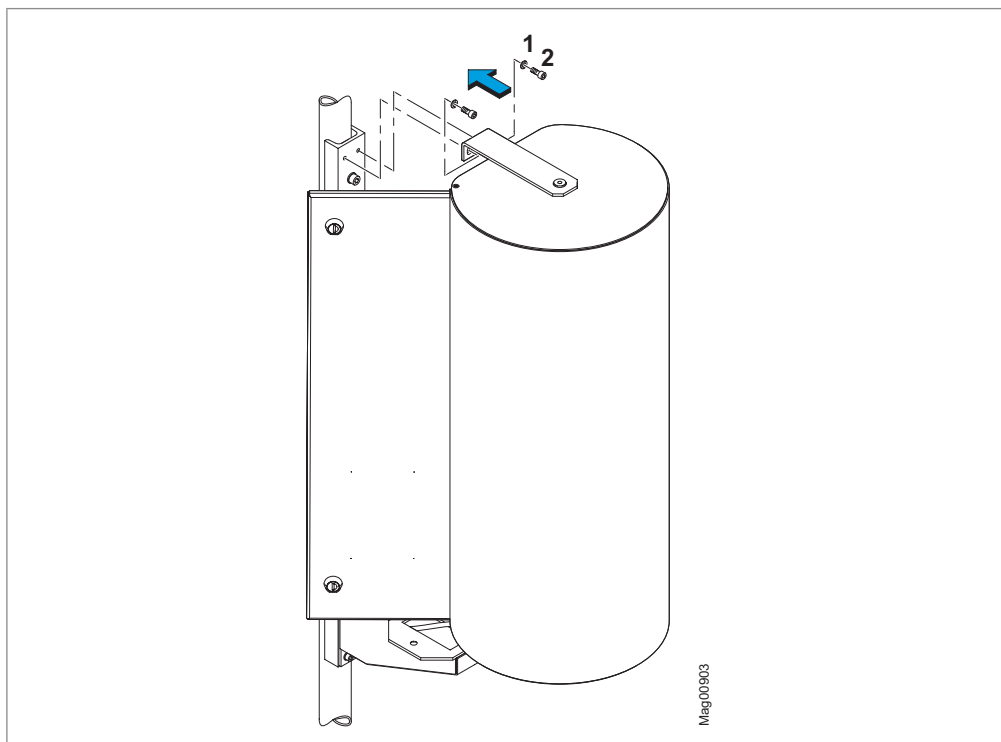

Fig. 56: Mounting the attachment angle

- 1 Spring washer A6
- 2 Screw M6 x 16

5. Align the mounting pillar by turning it.

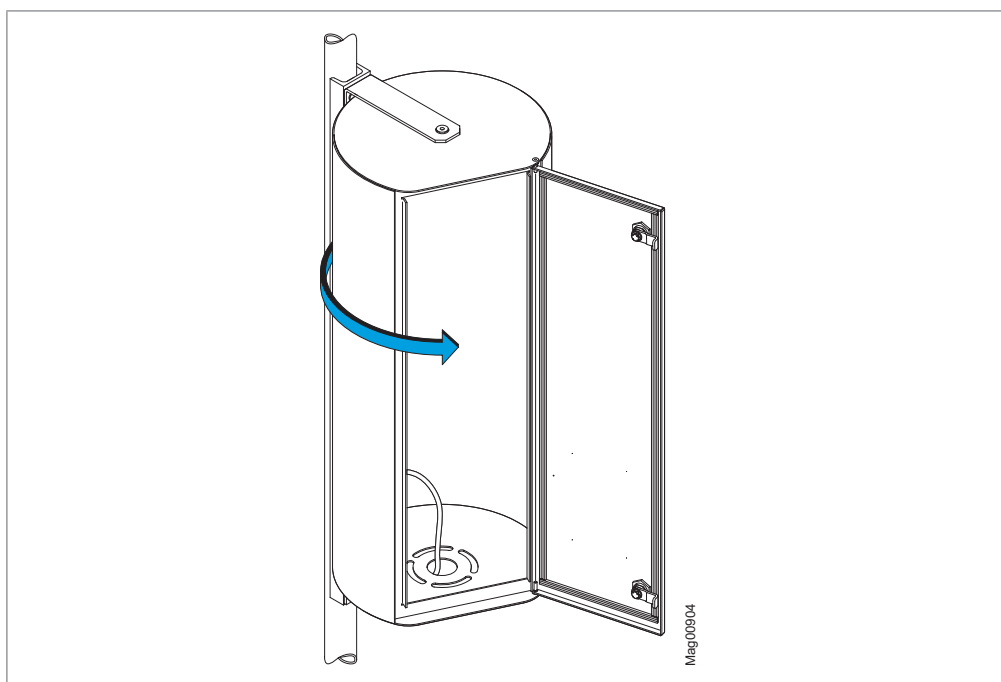

Fig. 57: Aligning the mounting pillar

6. Fix the mounting pillar to the lower holder.

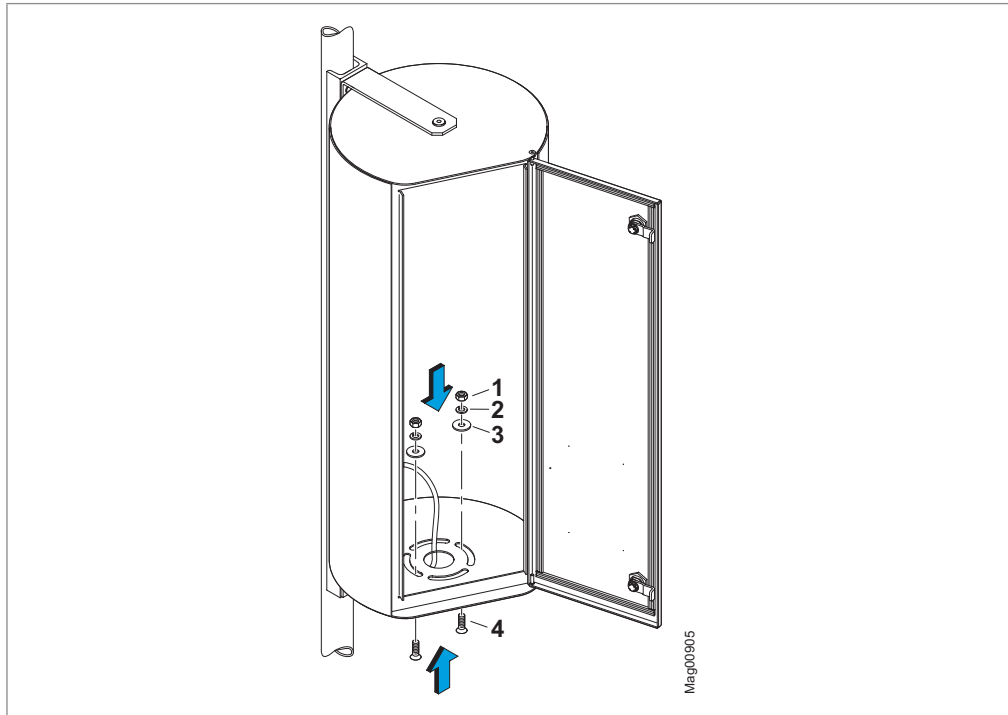

Fig. 58: Fixing the mounting pillar

- 1 Nut M8
- 2 Spring washer A8
- 3 Washer D8.4
- 4 Screw M8 x 25

7. Tighten the screw and nut on the upper attachment angle.

## 9 Electrical connection

### 9.1 Safety during electrical connection

#### Qualification of personnel

- › Technician
- › Qualified electrician
- ↗ Page 12, chapter 2.3.2.

#### Personal protective equipment

Wear the following personal protective equipment:

- › Work clothes
- › Protective gloves
- › Safety shoes
- › Protective helmet.

#### DANGER



#### Electric voltage!

Touching live parts can be lethal. Damage to the insulation or to individual components can be lethal.

- › Only qualified electricians or electrical safety experts may perform any work on the electrical system.
- › Before commencing any work, switch off power supply and secure against restarting. Test for absence of voltage.
- › Keep live parts free from moisture and dust. Intruding moisture or dust may cause a short circuit.
- › If the electrical connection is established at precipitation, e.g., rain or snow, intrusion of moisture must be prevented by suitable measures, such as a protective cover.
- › Install protective devices that are required by national and local regulations, such as e.g., residual current devices. These protective devices must be provided by the customer.
- › Observe the information on the type plate.
- › Close all covers after all work is completed.

**⚠ DANGER****Mortal danger from lightning and electric voltage!**

During or after a lightning struck the system, touching the components or being in the immediate vicinity of the system poses a danger to life.

- › When mounting outside, do not install and mount the pedestrian gate during thunderstorms.
- › Protect yourself in buildings or vehicles.

**NOTICE****Electromagnetic interference!**

The pedestrian gate is approved for industrial, residential, commercial, and business use. Operation in other electromagnetic environments may result in interferences or malfunction.

- › Place control lines and mains cables into separate conduits.
- › Customer access-control devices, signal transmitters and receivers must be EMC-tested and comply with the prescribed EMC limits. In this case, a Declaration of Conformity must be carried out by the customer.

## 9.2 Installing electrical protective devices

The protective devices that are required according to national and local regulations must be provided on site. This safety equipment is to be provided by the customer.

As a rule, the following protective devices must be installed:

- › Residual current device (RCD)
- › Circuit-breaker.
- › Lockable 2-pole main switch acc. to EN 60947-3.



## 9.3 Opening and closing the cover or service door



### IMPORTANT!

For safe operation, the support beam, the cover, and the service door must be earthed. The service door and the cover are earthed via protective earth conductors, an earthing point on the cover and an earthing point on the support beam.

### 9.3.1 Opening and closing the cover

#### Opening the cover

1. Open the service door with the supplied key.
2. Disconnect the protective earth conductor for the service door at the earthing point for the cover.
3. Put the service door aside.
4. Disconnect the protective earth conductor for the cover at the earthing point for the cover.

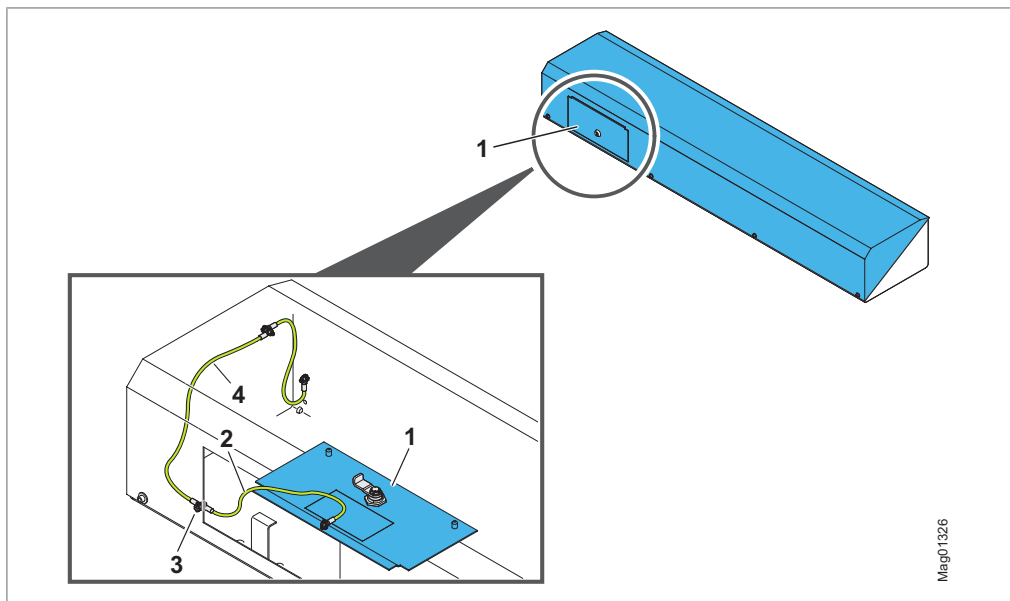

Fig. 59: Disconnect the protective earth conductor from the service door and cover

- 1 Service door
- 2 Protective earth conductor for service door
- 3 Hood earthing point
- 4 Protective earth conductor for cover

5. Loosen the screw of the cover.
6. Pull the cover to the front and remove it.

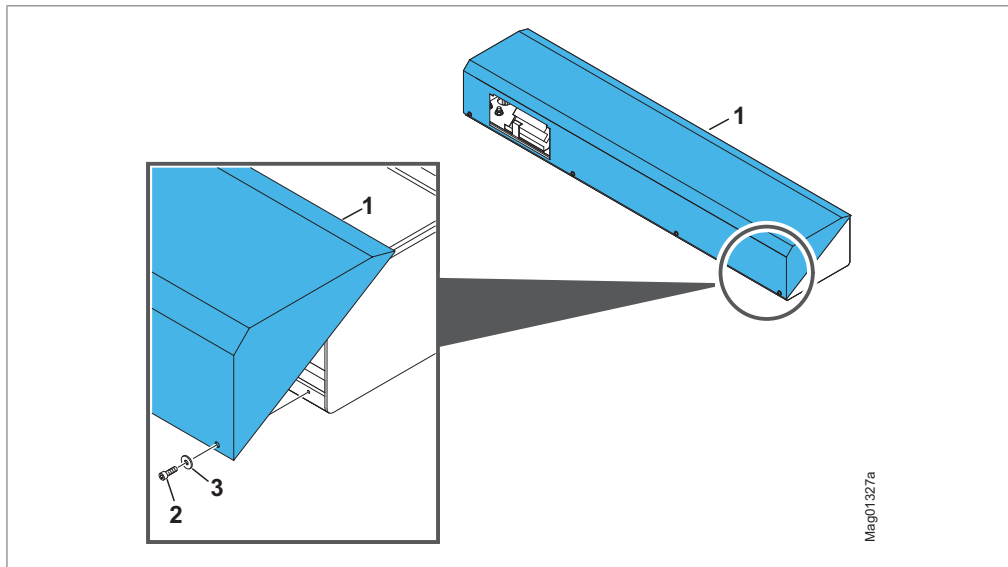

Fig. 60: Opening the cover

- 1 Cover
- 2 Screw
- 3 Washer

### Closing the cover

1. Put the cover onto the support beam from the front.
2. Secure the cover with the screws.

#### ⚠ DANGER

Danger to life if the protective earth conductor for the cover is not connected!

3. Connect the protective earth conductor for the cover to the earthing point for the cover.

#### ⚠ DANGER

Danger to life if the protective earth conductor for the service door is not connected!

4. Connect the protective earth conductor for the service door to the earthing point for the cover.
5. Close the service door.

### 9.3.2 Opening and closing the service door

#### Opening the service door

1. Open the service door with the supplied key.

#### Closing the service door

**⚠ DANGER**

Danger to life if the protective earth conductor for the service door is not connected!

1. Ensure that the protective earth conductor for the service door is located on the service door and connected to the cover.
2. Close the service door.

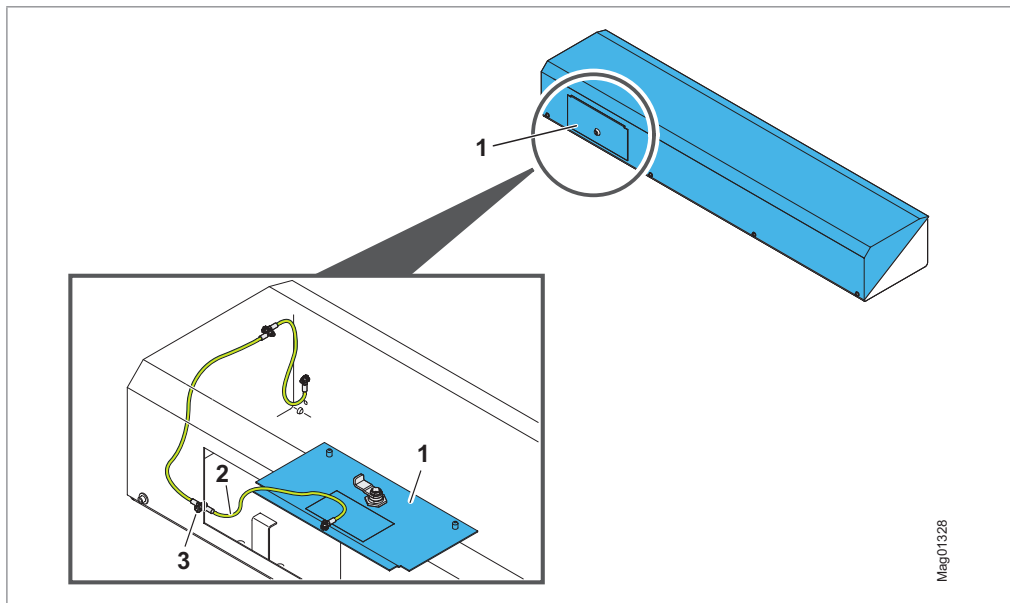

Fig. 61: Open the service door, grounding of the service door (exemplary representation)

- 1 Service door
- 2 Protective earth conductor for service door, earthed via earthing point support cover
- 3 Hood earthing point

## 9.4 Connecting the mains cable

### DANGER



#### Danger to life due to electric shock!

If the mains cable is not connected to the terminal clamps correctly, loosens from the connection clamps and touches the housing or cover, there is a direct danger to life from electric shock.

- › Only qualified electricians may perform any work on the electrical system.
- › Connect mains cable according to the following description.
- › Install electrical protective devices. ↗ Page 88, chapter 9.2.



#### IMPORTANT!

The wire cross-section of the mains cable must be between 1.5 and 2.5 mm<sup>2</sup>. Observe national regulations regarding cable length and corresponding wire cross-section.

1. Disconnect the pedestrian gate from the power supply. Ensure absence of voltage. Secure against reactivation.



Danger to life, electrical voltage!

2. Strip the mains cable and wires as per the following figure.

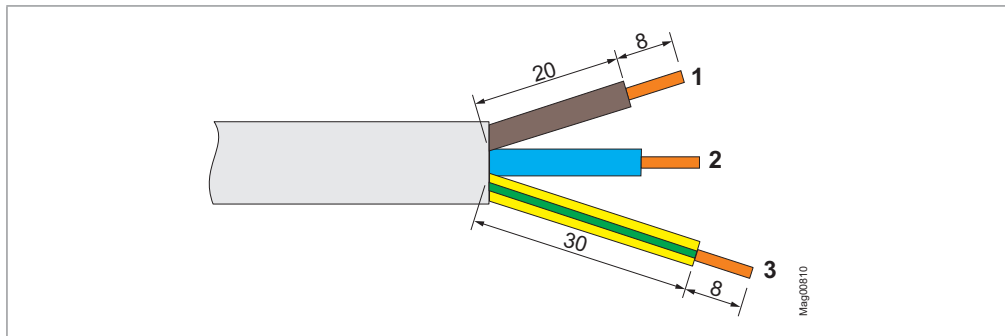

Fig. 62: Stripping (dimensions in mm)

- 1 Phase
- 2 Zero conductor
- 3 Protective earth conductor

3. Connect the mains cable to the terminals X1: L / N / PE in the support beam as shown in the following figures. ↗ Separate electrical circuit diagram.
  - › Place mains cable properly in the support beam. Observe that the line does not get into any moving parts and is not crushed by the cover.
  - › Secure the mains cable via the tension relief.

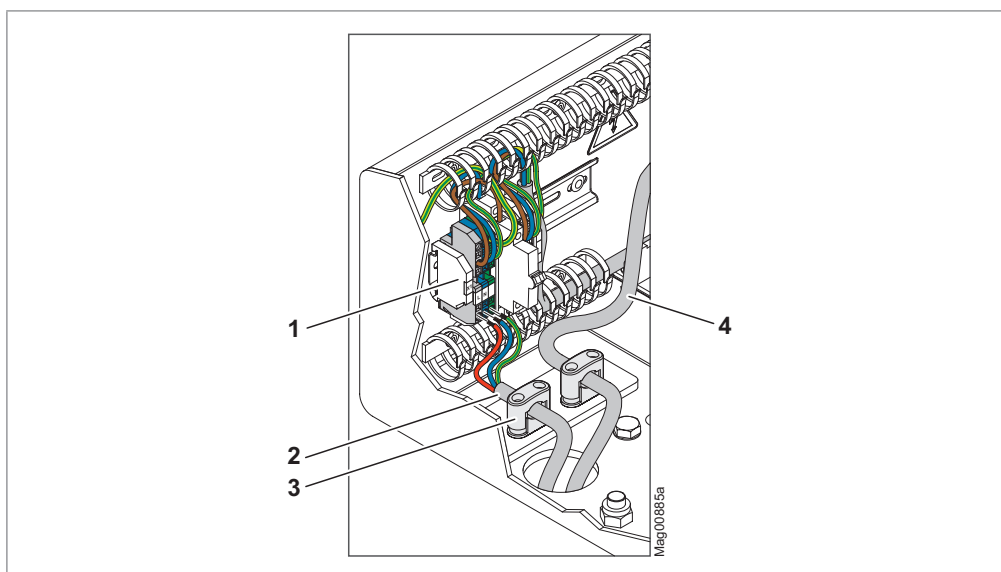

Fig. 63: Connecting the mains cable

- 1 Terminals mains cable X1
- 2 Mains cable
- 3 Tension relief
- 4 Further line

## 9.5 Connecting customer control lines



### IMPORTANT!

For connecting the control lines provided by the customer, see separate document "Description of control unit MGC (Doc.ID: 58170027)".

## 9.6 Connecting emergency opening contacts

↗ Separate wiring diagram and document “Description control unit MGC (Doc.ID: 58170027)”.

Connect fire brigade switches, emergency opening contacts, etc. to the “Emergency open” input. This input has the highest priority. The input function “Emergency open” is superordinate to all other input functions. As long as +24 V DC are present at this input, the pedestrian gate is in operation.

## 9.7 Mounting and connecting customer access-control devices

### DANGER



#### **Danger to life due to electric shock!**

Improper installation of the mounting pillar may cause electric shock and therefore potentially fatal injury.

- › Only qualified electricians may perform any work on the electrical system.
- › Connect the mains cable correctly to the terminals. Ensure that the mains cable cannot come free of the terminals and touch the housing or the door.
- › When using voltages above 25 V AC or 60 V DC, earth the housing or connection plate.
- › Use a voltage of no more than 25 V AC or 60 V DC on the operating front.

### **Mounting**

You may mount the access-control devices in the following positions, for example:

- › Optional mounting pillar: ↗ Page 79, chapter 8.
- › Mounting bracket on the cage half:  
Optionally you may order the attachment set AMWMPT for the mounting brackets by Magnetic.

### **Electrical connection**

The access-control devices are connected to the control unit MGC.

↗ Separate electrical circuit diagram.

## 9.8 Checking the electrical connections

Check the following after completing the electrical installation:

- › Does the power supply match the specification on the type plate?
- › Are the required protective devices installed?
- › Is the pedestrian gate connected according to electrical circuit diagram?
- › Is the emergency signal transmitter correctly connected?
- › Are the customer's signal transmitters and receivers correctly connected?
- › Are all screws tightened?
- › Is the support beam earthed?
- › Is the protective earth conductor for the cover connected?
- › Is the protective earth conductor for the service door connected?
- › Is the cover mounted correctly?
- › Is the service door closed?

## **10 Commissioning**

### **10.1 Safety during commissioning**

#### **Qualification of personnel**

- › Technician
- › Qualified electrician
- ↗ Page 12, chapter 2.3.2.

#### **Personal protective equipment**

Wear the following personal protective equipment:

- › Work clothes
- › Protective gloves
- › Safety shoes
- › Protective helmet.

### **10.2 Putting the pedestrian gate into operation**

Perform the following checks during commissioning:

- › Home position of the centre pillar
- › Function of the centre pillar in both directions
- › Function of the centre pillar in case of power failure
- › Function of the centre pillar in an emergency situation
- › Function of the optional displays for passage clear and passage locked
- › Function of the customer-side access-control devices



## 10.3 Switching the pedestrian gate on and off

### NOTICE



#### Restarting quickly!

Restarting the pedestrian gate too quickly can lead to damage of the equipment!

- › Wait at least 10 seconds after switching off the pedestrian gate before you switch the pedestrian gate on again.

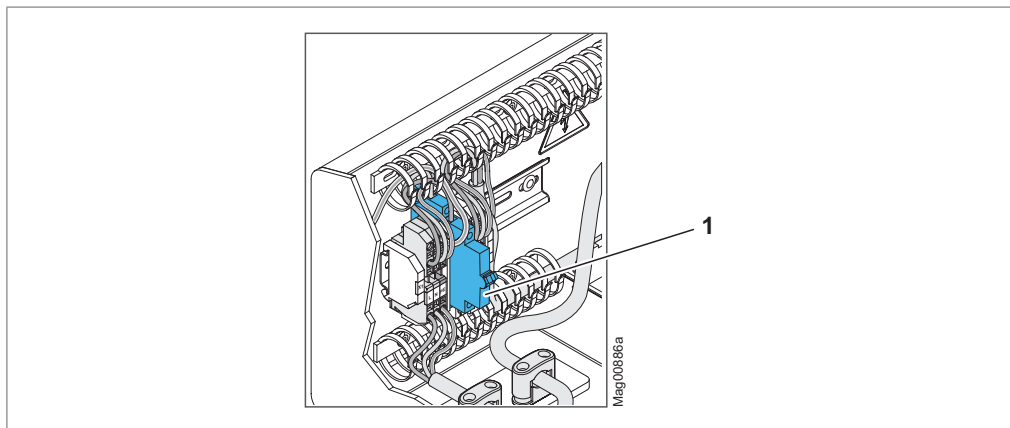

Fig. 64: Switching the pedestrian gate on and off

1 2-pin switch-off

1. Open the service door for the support beam. ↗ Page 91, chapter 9.3.2.
2. Switch the pedestrian gate on or off using the 2-pin switch-off.
3. Close the service door.

## 10.4 Parameterising the pedestrian gate

---



**IMPORTANT!**

For parameterisation see separate document “Description of control unit MGC (Doc.ID: 58170027)”.

---

## 11 Operation

The operation of the pedestrian gate depends on the connected access-control devices, signal transmitters and signal receivers and on the parameterisation of the control unit.

We recommend creating a description for the operation, depending on the connected devices and the parameterisation.

---



**IMPORTANT!**

For parameterisation see separate document “Description of control unit MGC (Doc.ID: 58170027)”.

---

## 12 Log book

The pedestrian gate must be checked at least once a year in accordance with the log book.

The log book “Full height turnstile MPT-333 / MPT-333 (Doc.ID: 58370033)” is included in the scope of delivery.

## 13 Cleaning and maintenance

### 13.1 Safety during cleaning and maintenance

#### Qualification of personnel

Cleaning

- › Operator

Cleaning and maintenance

- › Technician
- › Qualified electrician

➤ Page 12, chapter 2.3.2.

#### Personal protective equipment

Wear the following personal protective equipment:

- › Work clothes
- › Protective gloves
- › Safety shoes
- › Protective helmet.

## 13.2 Cleaning the pedestrian gate

The cleaning interval essentially depends on the environmental conditions and the climate.

### NOTICE



#### **Aggressive cleaning aids and substances!**

Aggressive detergents and consumables may damage or destroy components, electric cables, or the coating of the pedestrian gate.

- › Do not use cleaning agents with aggressive ingredients.

### 13.2.1 Cleaning the pedestrian gate from the outside

Clean the pedestrian gate at regular intervals.

- › Remove soiling appropriately.
- › Never use wet cloth.
- › For powder-coated components: Clean or pre-clean regularly with a damp cloth and then dry off carefully.
- › For stainless steel components: Clean or pre-clean regularly with a damp cloth and then dry off carefully. Clean with stainless steel detergent if required. We recommend the stainless steel polish from 3M. Apply a thin and even layer of stainless steel detergent and rub it dry by using a clean and dry disposable cloth.
- › For galvanised components: Wash off surfaces using water and a soft cloth. Remove stubborn marks as soon as possible using a standard commercial detergent for zinc (e.g., ROTOL New Formula A2).

### 13.2.2 Cleaning the support beam from the inside

NOTICE	
	<p><b>Improper cleaning!</b></p> <p>Cleaning with a vapour or pressure-jet cleaner will damage or destroy electrical components and cables.</p> <p>› Never clean the support beam with vapour or pressure-jet cleaners.</p>

1. Disconnect the pedestrian gate from the power supply. Ensure absence of voltage. Secure against reactivation.  
 **DANGER**  
Danger to life, electrical voltage!
2. Open cover. ↗ Page 89, chapter 9.3.1.
3. Use a vacuum cleaner to clean dust from the inside of the support beam.
4. Close cover.

### 13.3 Maintenance schedule

The components do not have to be replaced by default.

The work listed in the maintenance plan are visual inspections and functional checks that we either recommend for safe, optimum and trouble-free operation of the pedestrian gate or that are prescribed by official regulations, ordinances, rules, guidelines and/or standards.

**Corrective action**

Interval	Work	Personnel
Monthly	Check the pedestrian gate for damage from the outside.	Operator
Every 6 months	Check the locking comb or cage half with blocking bracket, cage half and centre pillar for damage.	Technician
	Check the support beam for damage from inside and outside. If necessary, clean support beam and correct defect in paint work.	Technician
	Check the floor bearing for the centre pillar for ease of movement. Adjust play if necessary.	Technician
	Check the screw connection of the flange connection of the centre pillar.	Technician
	Check the function of the locking mechanism for the centre pillar.	Technician
	Check the input function "emergency open".	Technician
	Check the function of the external residual current device.	Qualified electrician
Every 12 months-	Check the electrical lines for damage.	Qualified electrician
	Check all electrical connections for tightness.	Qualified electrician
	Check the earthing of the support beam, cover, and service door for damage and tight fit. ↗ Page 16, chapter 2.9.	Qualified electrician
	Check signs and labels for completeness and legibility.	Technician
	Perform work as per the supplied log book.	Technician
	Check the attachment screws of the pedestrian gate.	Technician
According to the operator	Check emergency function.	Operator

Table 10: Maintenance schedule

**14 Corrective action****IMPORTANT!**

In case of a fault, please contact Magnetic Customer Support.

## 15 Spare parts and repair

### 15.1 Spare parts

#### NOTICE



#### Wrong and faulty spare parts!

Incorrect or defective spare parts can result in damage, malfunctions or total failure and also impair safety.

› Use only the manufacturer's original spare parts.

Spare parts can be purchased from your authorised dealer. The address can be found on your delivery receipt, invoice or on the back of these operating instructions.

Spare part lists can be obtained on request.

### 15.2 Changing and adjusting proximity sensors

➤ Separate electrical circuit diagram.

The locking unit is equipped with two inductive proximity sensors. These proximity sensors are used to detect the end position of the centre pillar.

The designation of the proximity sensors corresponds to the designation in the electrical circuit diagram. The proximity sensors are marked with the appropriate symbol for normally closed or normally open contact.

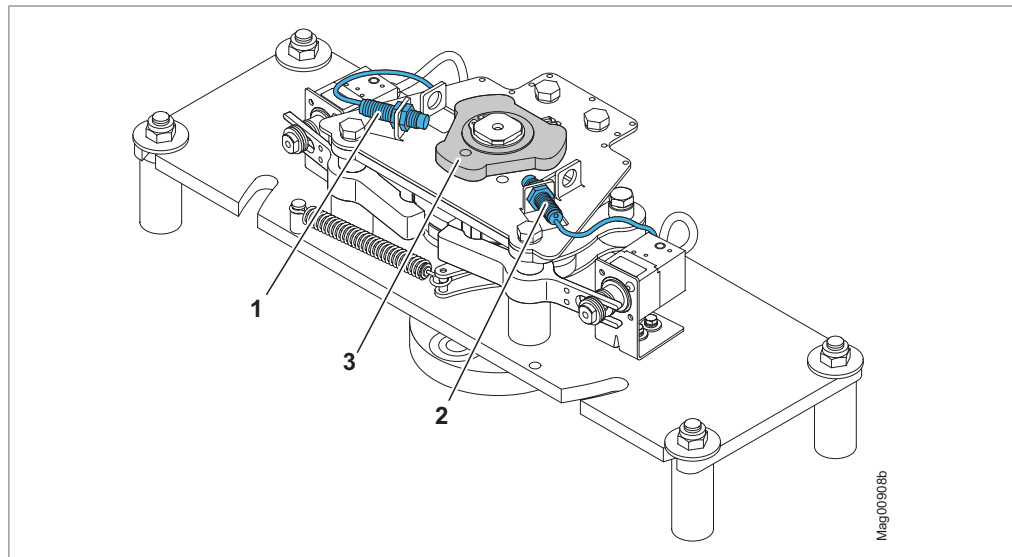

Fig. 65: Proximity sensors to detect the end position of the centre pillar, locking unit for MPT-3x3 (3x120°)

- 1 Proximity sensor -B1, normally closed (NC)
- 2 Proximity sensor -B2, normally open
- 3 Switching cam of the cam plate, countersink marks the home position

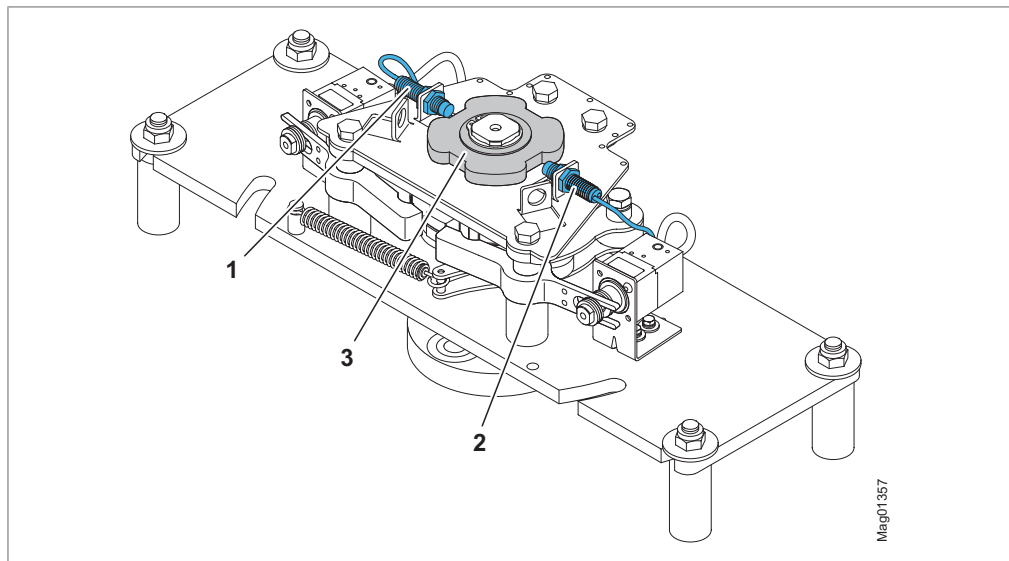

Fig. 66: Proximity sensors to detect the end position of the centre pillar, locking unit for MPT-3x3 (4x90°)

- 1 Proximity sensor -B1, normally closed (NC)
  - 2 Proximity sensor -B2, normally open
  - 3 Switching cam of the cam plate, countersink marks the home position
1. Disconnect the pedestrian gate from the power supply. Ensure absence of voltage. Secure against reactivation.
    - ⚠ DANGER
    - Danger to life, electrical voltage!
  2. Loosen the connection line of the proximity sensor at the terminals.
  3. Dismount the proximity sensor. Loosen the nut for this purpose.
  4. Mount new proximity sensor. Make sure that the distance to the cam is between 0.5 and 2.0 mm.
  5. Attach the proximity sensor. Tighten the nut.
  6. Connect the connection line of the proximity sensor at the terminals.
  7. Switch on power supply.
  8. Check if the end position is recognised. If the end position is not detected, check the distance to the switching cams.



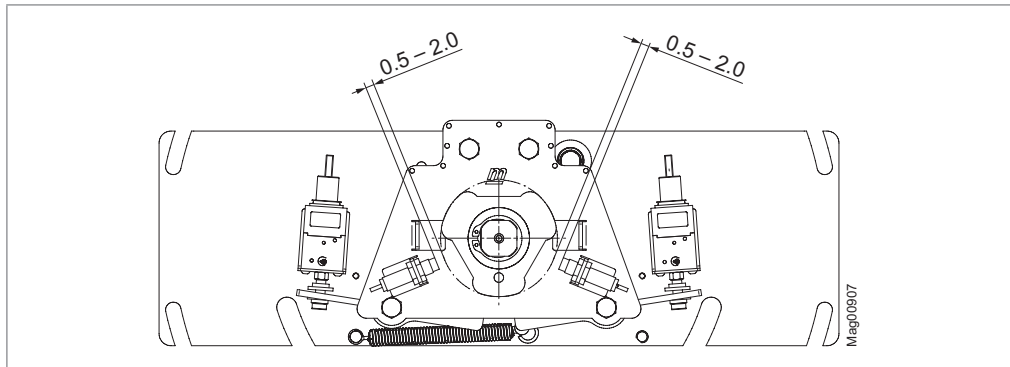

Fig. 67: Distance proximity sensor – switching cam for locking unit for MPT-3x3 (3x120°)

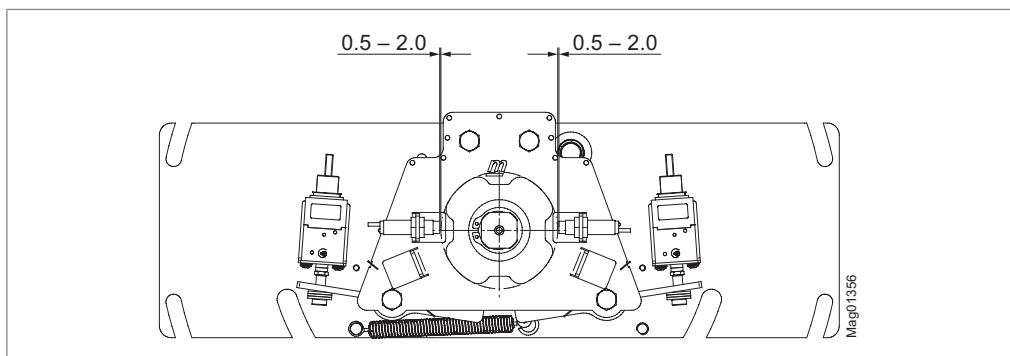

Fig. 68: Distance proximity sensor – switching cam for locking unit for MPT-3x3 (4x90°)

## 16 Conversion

### 16.1 Safety during conversion

#### Qualification of personnel

Cleaning and maintenance

- › Technician
- › Qualified electrician

↗ Page 12, chapter 2.3.2.

#### Personal protective equipment

Wear the following personal protective equipment:

- › Work clothes
- › Protective gloves
- › Safety shoes
- › Protective helmet.

### 16.2 Converting the locking unit

By default, the locking unit is delivered with the configuration “rotating freely when de-energised”.

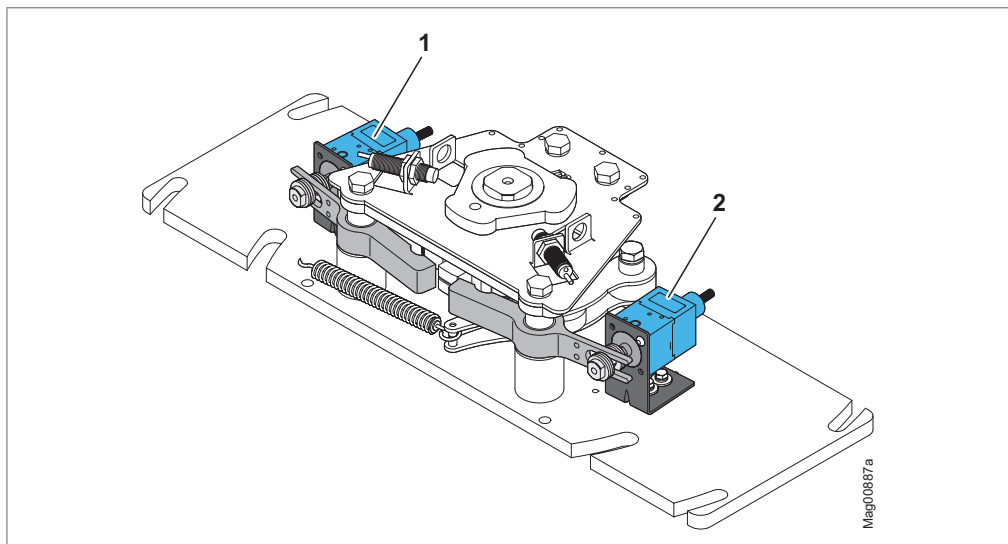

Fig. 69: Locking unit configuration “rotating freely when de-energised” – locking unit for MPT-3x3 (3x120°) shown here, designations and position of the magnets for locking unit MPT-3x3 (4x90°) are identical

- 1 Magnet RL1
- 2 Magnet RL2



**IMPORTANT!**

You can modify the locking unit into the “Locked when de-energised” configuration. You must then parameterise the turnstile for the “Locked when de-energised” configuration in the “Gate HW” menu. For parameterisation see separate document “Description of control unit MGC (Doc.ID: 58170027)”.

Characteristic	Rotating freely when de-energised	Locked when de-energised
Function	The centre pillar can be rotated in the event of a power failure. The passage is free for both directions.	In the event of a power failure, the passage is blocked for both directions. The centre pillar is locked.
Required washers	6 washers: 3 inner, 3 outer	5 washers: 3 inner, 2 outer

Table 11: Features “rotating freely when de-energised” and “locked when de-energised”

**Convert locking unit for configuration “Locked when de-energised”**

1. Disconnect the pedestrian gate from the power supply. Ensure absence of voltage. Secure against reactivation.



**DANGER**  
Danger to life, electrical voltage!

2. Open cover. ↗ Page 89, chapter 9.3.1.

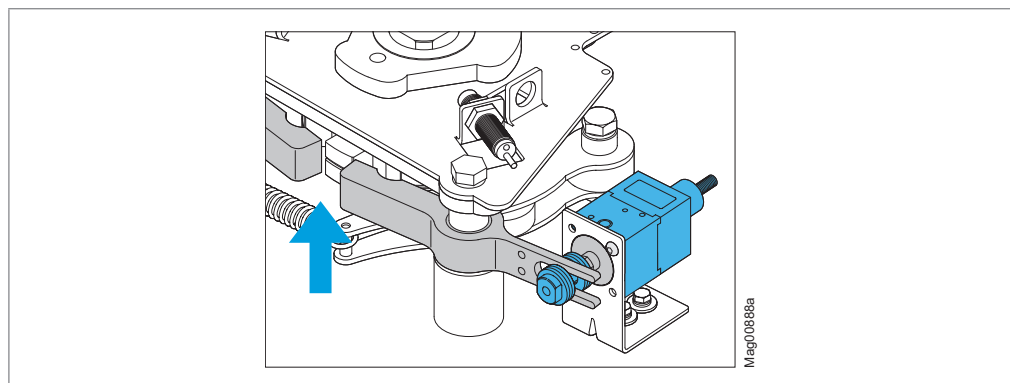

Fig. 70: Locking unit configuration “rotating freely when de-energised” (here locking unit for MPT-3x3 (3x120°) shown)



8. Place the washers on the threaded rod of the magnet as shown in the figure. Place 3 washers between magnet and holder. Place 2 washers between notch lever and union nut.
9. Screw the union nut onto the threaded rod.
10. Mount the magnet on the holder.
11. Tighten the union nut and secure with threadlocker such as Loctite 241.

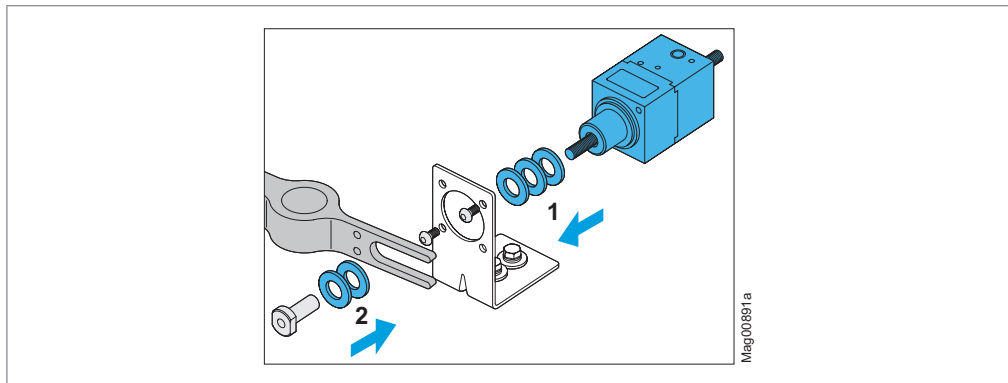

Fig. 73: Mount magnet, washers, and union nut (locked when de-energised.)

- 1 3 washers between magnet and holder
- 2 2 washers between notch lever and union nut

12. Convert magnets on the other side, e.g., magnet RL1.

✓ The locking unit has been modified for the “Locked when de-energised” configuration.

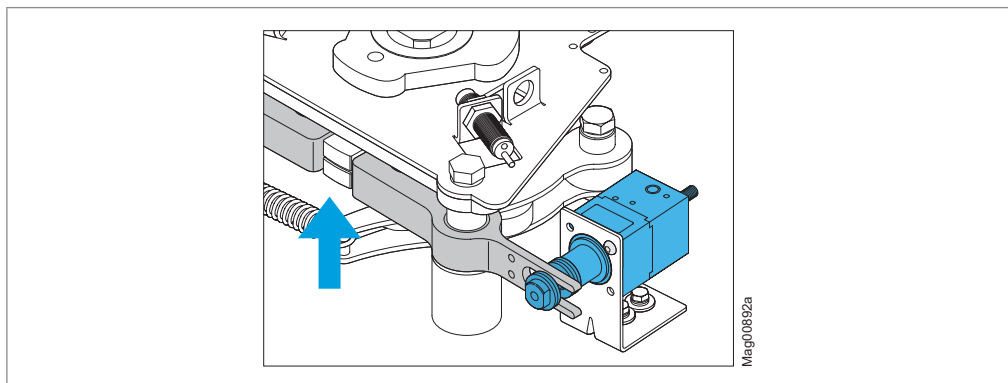

Fig. 74: Locking unit configuration “locked when de-energised”  
(locking unit for MPT-3x3 (3x120°) is shown here)

13. Parameterise the turnstile for the “locked when de-energised” configuration in the “Gate HW” menu on the control unit MGC.

## 17 **Customer service**

Our customer service can be contacted for any technical advice. Notices concerning the responsible contact person can be retrieved by telephone, fax, email or via the Internet at any time, refer to manufacturer's address on page 2.



**IMPORTANT!**

In order to enable fast handling note the data of the type plate such as type, serial number, version, etc., before calling.

---

## 18 Decommissioning

The pedestrian gate must be taken out of service in the following cases:

- › The pedestrian gate is mounted at a different location.
- › The pedestrian gate is decommissioned for more than 6 months.

If you only want to deactivate the pedestrian gate for a short time, see the “Switching the pedestrian gate on and off” section. ↗ Page 97, chapter 10.3.

### 18.1 Safety during decommissioning

#### Qualification of personnel

- › Technician
- › Qualified electrician

↗ Page 12, chapter 2.3.2.

#### Personal protective equipment

Wear the following personal protective equipment:

- › Work clothes
- › Protective gloves
- › Safety shoes
- › Protective helmet.

### 18.2 Taking the pedestrian gate out of service

1. Switch off the pedestrian gate. ↗ Page 97, chapter 10.3.
2. Disconnect the pedestrian gate from the power supply.
3. If necessary, dismount the pedestrian gate.
4. Store the pedestrian gate or its components correctly. ↗ Page 37, chapter 5.4.

## 19 Dismounting and disposal

### 19.1 Safety during dismounting and disposal

#### Qualification of personnel

- › Technician
- › Qualified electrician
- ↗ Page 12, chapter 2.3.2.

#### Personal protective equipment

Wear the following personal protective equipment:

- › Work clothes
- › Protective gloves
- › Safety shoes
- › Protective helmet.

### 19.2 Dismounting and disposal of the system

#### Requirements

- › The pedestrian gate is out of order. ↗ Page 111, chapter 18.2.
1. Disassemble the pedestrian gate into individual components.
  2. Recycle parts by type and material. Dispose of non-recyclable materials in an environmentally friendly manner. Observe local and national laws and guidelines.
- ✓ The pedestrian gate is dismantled and disposed of.



# EU-Declaration of Conformity



The manufacturer MAGNETIC AUTOCONTROL GmbH hereby declares for the product supplied by him:

Designation	<b>Full height turnstile</b>
Type	MPT-3*3
From serial number	A00000001

The conformity according to:

**Directive 2006/42/EC** (Machine directive) amended by **2009/127/EC**

**Directive 2014/30/EU** (EMC directive)

**Directive 2011/65/EU** (RoHS 2 directive)

Applied harmonised standards (or parts hereof):

**EN ISO 12100:2010**

Safety of machinery – General principles for design – Risk assessment and risk reduction

**EN 60204-1:2018**

Safety of machinery – Electrical equipment of machines – Part 1: Specifications for general requirements

**EN 61000-6-2:2005/AC:2005**

Electromagnetic compatibility (EMC) – Part 6-2: Generic standard – Immunity for industrial environments

**EN 61000-6-3:2007/A1:2011/AC:2012**

Electromagnetic compatibility (EMC) – Part 6-3: Generic standard – Emission standard for residential, commercial and light-industrial environments

**EN ISO 13849-1:2015**

Safety of machinery – Safety-related parts of control systems – Part 1: General principles for design

This declaration is not a guarantee of characteristics in the sense of product liability law. The safety regulations of the operating instructions have to be observed.

MAGNETIC AUTOCONTROL GmbH  
Grienmatt 20-28  
79650 Schopfheim

Documentation Engineer  
Mr. Stefan Wellinger

Schopfheim, 01/08/2023

Place and date

Signature



## Index

### A

Access-control devices	
Connect .....	94
Installing .....	94
Attachment material .....	42

### B

Base frame.....	43
-----------------	----

### C

Cage half	
MPT-333 (3x120°).....	29, 30
MPT-333 (4x90°).....	31
Cage half with blocking bracket.....	30
Centre pillar.....	29, 30, 31
Changes .....	10
Cleaning.....	99, 100
Commissioning.....	96
Control lines	
Connect .....	93
Control unit MGC	
Technical data.....	28
Corrective action .....	102
Cover .....	29, 30, 31
Close.....	89
Open.....	89
Customer service.....	110

### D

Decommissioning .....	111
Design.....	29
MPT-333 (3x120°).....	29
MPT-333 (3x120°) with “KHSB” option...	30
MPT-333 (4x90°).....	31
Dimensions.....	18
MPT-333 (3x120°).....	18
MPT-333 (3x120°) with “KHSB” option...	21
MPT-333 (4x90°).....	24
Dismounting .....	112
Disposal .....	112

### E

Earthing	
Cover .....	16
Service door .....	16
Support beam.....	16
Electrical connection .....	87
Check.....	95
Technical data.....	27

Emergency opening.....	94
------------------------	----

Emissions.....	27
----------------	----

### Empty conduit plan

MPT-333 (3x120°).....	47
-----------------------	----

MPT-333 (3x120°) with “KHSB” option...	48
--	----

MPT-333 (4x90°).....	49
----------------------	----

### Empty conduits

Requirements.....	46
-------------------	----

### Entry

Definition.....	33
-----------------	----

EU Declaration of Conformity.....	113
-----------------------------------	-----

### Exit

Definition.....	33
-----------------	----

### F

Floor bearing .....	29, 30, 31
---------------------	------------

### Foundation

Build .....	46
-------------	----

Requirements.....	44, 45
-------------------	--------

### Foundation plan

MPT-333 (3x120°).....	47
-----------------------	----

MPT-333 (3x120°) with “KHSB” option...	48
--	----

MPT-333 (4x90°).....	49
----------------------	----

Function.....	32
---------------	----

### I

Illumination .....	29, 30, 31
--------------------	------------

Intended use.....	10
-------------------	----

### K

KHSB. ....	See Cage half with blocking bracket
------------	-------------------------------------

### L

#### Left

Definition.....	33
-----------------	----

Locking comb.....	29, 31
-------------------	--------

#### Locking unit centre pillar

Converting.....	106
-----------------	-----

Locked when de-energised.....	109
-------------------------------	-----

MPT-3x3 (3x120°).....	60
-----------------------	----

MPT-3x3 (4x90°).....	73
----------------------	----

Rotating freely when de-energised .....	107
---	-----

Log book .....	98
----------------	----

### M

#### Magnet

RL1.....	106
----------	-----

RL2.....	106
----------	-----

#### Mains cable

Connect .....	92
---------------	----

Maintenance schedule .....	101
----------------------------	-----

Misuse .....	10
--------------	----

Modifications.....	10	Sleeves with inner thread.....	47, 48, 49, 50
Mounting.....	41	Spare parts .....	103
Mounting pillar.....	79	Storage .....	37
MPT-333 (3x120°).....	51	Support beam	
MPT-333 (3x120°) with “KHSB” option...	51	Close.....	89
MPT-333 (4x90°).....	66	MPT-333 (3x120°).....	29, 30
Preparations .....	50	MPT-333 (4x90°).....	31
Mounting bracket.....	29, 30	Open.....	89
Mounting pillar.....	29, 30, 31	Switching off.....	97
Mounting.....	79	Switching on .....	97
<b>N</b>		<b>T</b>	
Notice		Target groups.....	11
Illustration .....	8, 9	Technical data.....	18
<b>O</b>		Transport .....	37
Operating conditions.....	27	Twilight switch.....	29, 30, 31
Operation .....	98	Type plate .....	40
Operator		<b>U</b>	
Responsibility .....	11	Unpacking.....	38
<b>P</b>		<b>W</b>	
Parameterisation .....	98	Warning Notes	
Personal protective equipment .....	13	Illustration .....	8
Personnel		<b>Z</b>	
Qualification .....	12	ZC (zone controlled) .....	33, 34
Protective devices		ZNC (zone not controlled) .....	33, 34
Install.....	88	Zone controlled .....	33, 34
Proximity sensors locking unit		Zone not controlled.....	33, 34
-B1.....	103, 104		
-B2.....	103, 104		
Changing.....	103		
MPT-3x3 (3x120°) .....	103		
MPT-3x3 (4x90°) .....	104		
Set .....	105		
<b>Q</b>			
Qualification			
Personnel .....	12		
<b>R</b>			
Receipt of goods.....	35		
Repair .....	103		
Right			
Definition.....	33		
<b>S</b>			
Safety.....	10		
Scope of delivery .....	39		
Service door .....	29, 30, 31		
Close.....	89, 91		
Open.....	89, 91		







---

**MAGNETIC AUTOCONTROL GMBH**

Grienmatt 20  
D-79650 Schopfheim  
Germany

Phone +49 7622 695 5  
Fax +49 7622 695 802  
info@magnetic-germany.com  
www.magnetic-access.com

Sales partner

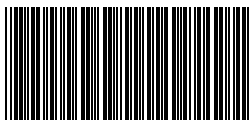

F10044680

Doc. ID: 58170036EN  
Version 00